

Penetrative Tilt Legs

Code-Compliant Planning and Installation Guide V 5.1
Complying with AS/NZS1170.2-2011 AMDT 2-2016



Introduction

The Clenergy PV-ezRack® SolarRoof Tilt Legs has been developed as a universal PV-mounting system for roof-mounting on pitched and flat roofs. The use of patented aluminium base rails, Z-Module technology and telescopic mounting technology eliminates custom cutting and enables fast installation.

Please review this manual thoroughly before installing PV-ezRack® SolarRoof Tilt Legs.

This manual provides:

- 1) Supporting documentation for building permit applications relating to PV-ezRack® SolarRoof Tilt Legs Universal PV Module Mounting System,
- 2) Planning and installation instructions.

List of contents

Introduction	01
Planning	02 - 13
Tools & Components	14
System Overview	15 - 18
Installation Instruction	19 - 22
Certification	23 - 43

The PV-ezRack® SolarRoof Tilt Legs parts, when installed in accordance with this guide, will be structurally sound and will meet the AS/NZS1170.2:2011 Amdt 2- 2016 standard. During installation, and especially when working on the roof, please comply with the appropriate Occupational Health and Safety regulations. Please also pay attention to any other relevant State or Federal regulations. Please check that you are using the latest version of the Installation Manual, which you can do by contacting Clenergy Australia via email on sales@clenergy.com.au, or contacting your local distributor in Australia.

Product Warranty:

Please refer [PV-ezRack® Product Warranty](#) on our website.

The installer is solely responsible for:

- Complying with all applicable local or national building codes, including any updates that may supersede this manual;
- Ensuring that PV-ezRack and other products are appropriate for the particular installation and the installation environment;
- Using only PV-ezRack parts and installer-supplied parts as specified by PV-ezRack project plan (substitution of parts may void the warranty and invalidate the letter of certification);
- Recycling: Recycle according to the local relative statute;
- Removal: Reverse installation process;
- Ensuring that there are no less than two professionals working on panel installation;
- Ensuring the installation of related electrical equipment is performed by licenced electricians;
- Ensuring safe installation of all electrical aspects of the PV array, This includes adequate earth bonding of the PV array and PV-ezRack® SolarRoof components as required in AS/NZS 5033: 2021;
- Ensuring that the roof, its rafters/purlins, connections, and other structural support members can support the array under building live load conditions;
- Ensuring that screws to fix interfaces have adequate pullout strength and shear capacities as installed;
- Maintaining the waterproof integrity of the roof, including selection of appropriate flashing;
- Verifying the compatibility of the installation considering preventing electrochemical corrosion between dissimilar metals. This may occur between structures and the building and also between structures, fasteners and PV modules, as detailed in AS/NZS 5033: 2021;

Planning

Determine the wind region of your installation site

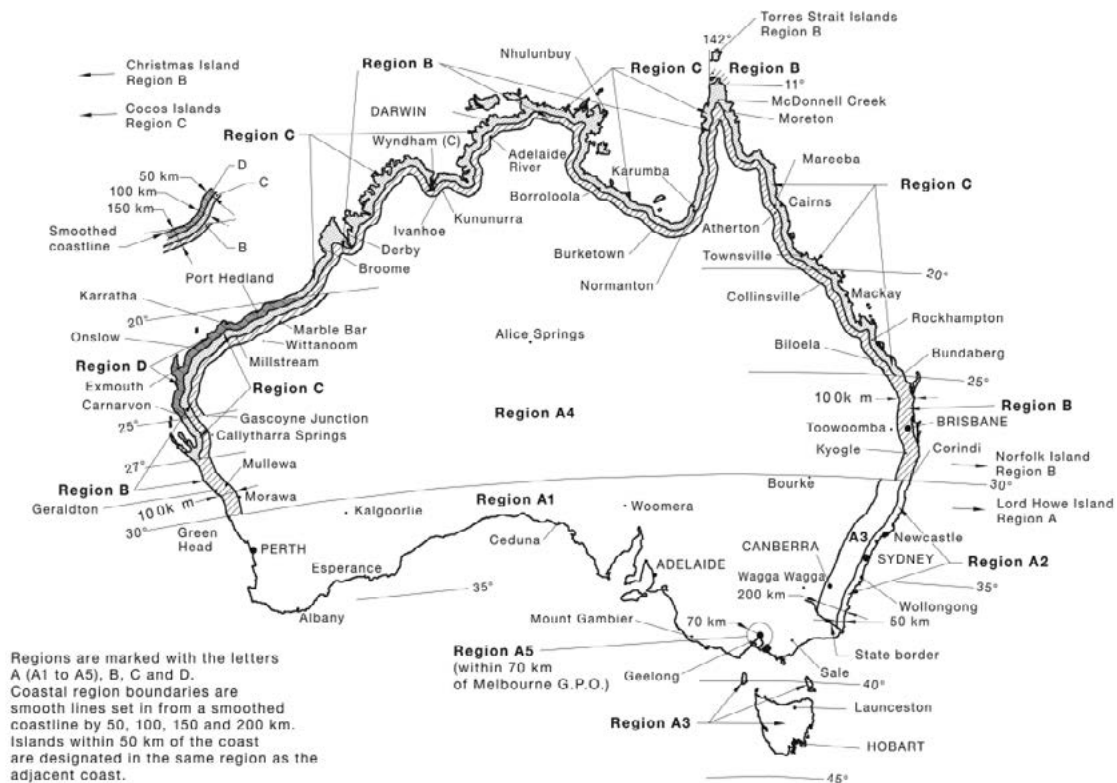

Region Definition

Wind regions are pre-defined for the whole of Australia by the Australian Standard 1170.2. The Wind Region is an independent factor of surrounding topography or buildings.

- Most of Australia is designated Region A which indicates a Regional Wind Velocity of 43 m/s with wind average recurrence of 200 years.
- Some areas are designated Region B (52 m/s). Local authorities will advise if this applies in your area.
- Region C areas (64 m/s) are generally referred to as Cyclonic and are generally limited to northern coastal areas. Most Region C zones end 100km inland.
- Region D (79 m/s) is Australia's most extreme Cyclonic Region, located between the town of Carnarvon and Pardoo Station in Western Australia.

Determine the Terrain Category

You will need to determine the terrain category to ensure the installation meets the required standard.

Terrain Category 1 (TC1) – Very exposed open terrain with few or no obstructions and enclosed, limited-sized water surfaces at serviceability and ultimate wind speeds in all wind regions, e.g. flat, treeless, poorly grassed plains; rivers, canals and lakes; and enclosed bays extending less than 10km in the wind direction.

Terrain Category 1.5 (TC1.5) – Open water surfaces subjected to shoaling waves at serviceability and ultimate wind speeds in all wind regions, e.g. near-shore ocean water; larger unenclosed bays on seas and oceans; lakes; and enclosed bays extending greater than 10km in the wind direction. The terrain height multipliers for this terrain category shall be obtained by the linear interpolation between the values for the TC1 and TC2.

Terrain Category 2 (TC2) – Open terrain, including grassland, with well-scattered obstructions having heights generally from 1.5m to 5m, with no more than two obstructions per hectare, e.g. farmland and cleared subdivisions with isolated trees and uncut grass.

Terrain Category 2.5 (TC2.5) – Terrain with a few trees or isolated obstructions. This category is intermediate between TC2 and TC3 and represents the terrain in developing outer urban areas with scattered houses, or larger acreage developments with fewer than ten buildings per hectare. The terrain-height multipliers for this terrain category shall be obtained by linear interpolation between the values for the TC2 and TC3.

Terrain Category 3 (TC3) – Terrain with numerous closely spaced obstructions having heights generally from 3m to 10m. The minimum density of obstructions shall be at least the equivalent of 10 house sized obstructions per hectare, e.g. suburban housing or light industrial estates.

Terrain Category 4 (TC4) – Terrain with numerous larger, high (10m to 30m tall) and closely-spaced buildings, such as large city centers and well-developed industrial complexes.

If your installation site is not at TC 2, 2.5 or 3, please contact Clenergy to obtain a project specific engineering certificate to support your installation.

Determine the Height of the Installation Site

This document provides sufficient information for the PV-ezRack® SolarRoof Tilt Legs system installation up to heights of 30 meters. If your installation site is more than 30 meters high please contact Clenergy to obtain project specific engineering certificate to support your installation.

Determine Roof slope and Tilt Leg Angle

The PV-ezRack® SolarRoof Tilt Legs system is suitable for roof slope up to 22° for rails running perpendicular to the roof slope (including standard and reverse tilt), and up to 10° for rails running parallel to the roof slope. See the diagrams of 3 different scenarios below.

Please always keep back leg tilt within 30° - 90° from roof plane or horizontal depending on certain scenario.

Standard Tilt – Rails perpendicular to Roof Slope

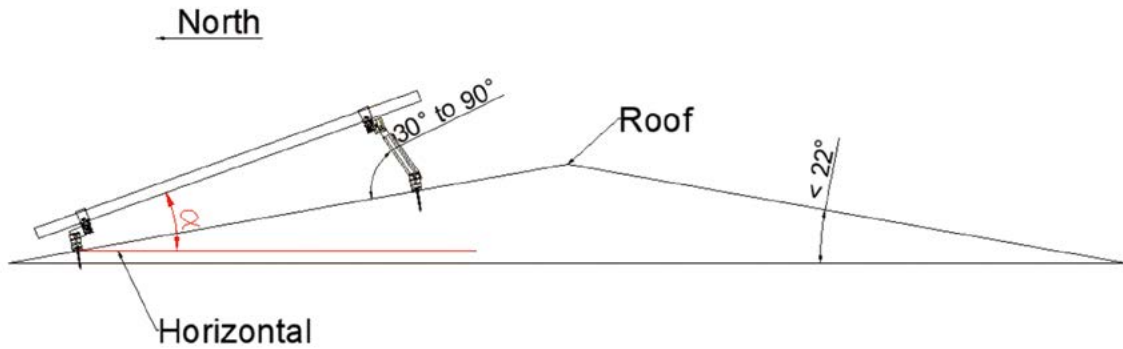

Reverse Tilt – Rails perpendicular to Roof Slope

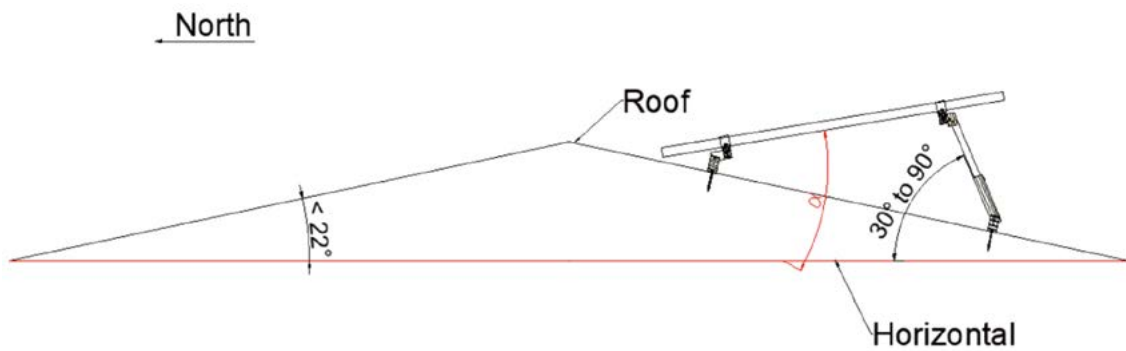

Standard Tilt – Rails parallel to Roof Slope

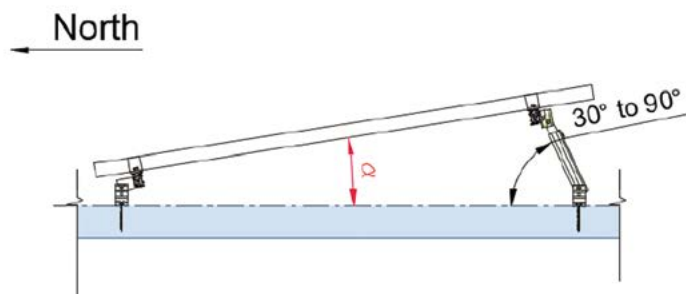
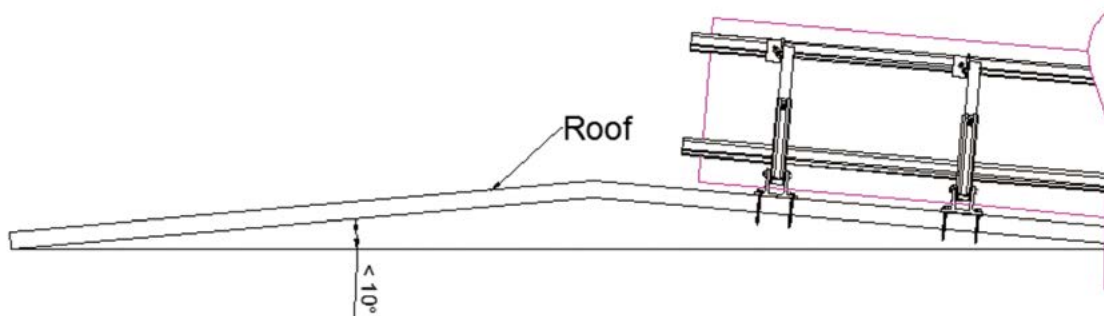

Determine the Installation Area of Roof

There are 4 different roof zones for tilt leg installation: Internal Zone, Intermediate Zone, Edge Zone and Corner Zone. Please see diagrams and steps below to define area of each zone.

- Step 1.** Determine building height (h), width (b) and length (d).
- Step 2.** Choose the lowest value between "h", "b x 0.2" and "d x 0.2".
- Step 3.** The lowest value on Step 2, equates to a.

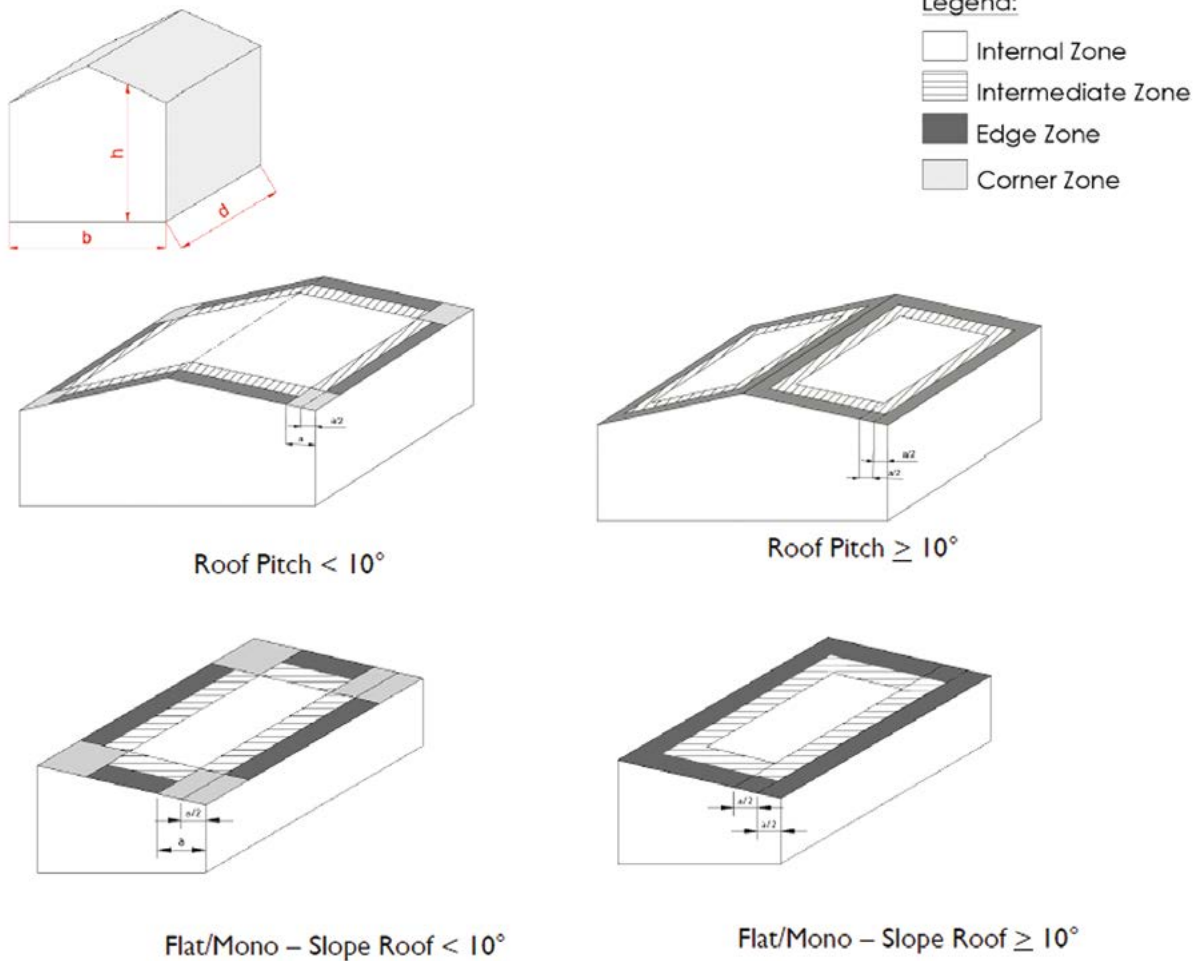

Verify Purlin Properties of Building

Please verify purlin properties of building, which could affect the interface spacing. Tilt legs spacing on in the certification letter is based on steel purlin G450 1.5 mm thick or 35 mm Timber F7 (Pine). For example, if the steel purlin is less than 1.5 mm thick, the corresponding reduction factor of interface spacing will be applied. Please refer generic notes 6-7 for details.

Determine Two Screws or One Screw Installations of Tilt Legs

There are options of using two screws or one screw for installations of adjustable and fixed tilt legs, depending on the project details, like required support spacing, purlin spacing, rib spacing of roof sheet and so on. Please find both two screws and one screw engineering certificates at the end of installation guides for max support spacing.

Determine the Maximum Rail Support Spacing

Please refer to the Certification Letter and Tilt Legs Spacing Table. If a project specific Certification Letter has been provided, please refer to the support spacing in this letter.

Verify Maximum Rail End Overhang

Rail end overhang should not be over 40% of the Tilt Legs spacing. For example, if the Tilt Legs spacing is 1500mm, the Rail end overhang can be up to 600mm only.

The application of Adjustable Tilt Legs

Following the tilt angle rules of 2.4 on the north or south facing roof, the actual panel tilt angles using the adjustable tilt legs installed at the different purlin spacing could be applicable or not. Please see the table and side view diagrams below.

Application of Adjustable Tilt Legs																
Purlin spacing		1200 mm					1400 mm					1700 mm				
	Product	10°	15°	30°	45°	60°	10°	15°	30°	45°	60°	10°	15°	30°	45°	60°
1650 mm panel in portrait	ER-TL-10/15	✓ (1)	✓ (2)	×	×	×	✓ (6)	×	×	×	×	×	×	×	×	×
	ER-TL-15/30	×	×	×	×	×	×	✓ (8)	×	×	×	×	×	×	×	×
	ER-TL-30/60	×	×	✓ (3)	✓ (4)	×	×	×	✓ (10)	✓ (12)	×	×	×	✓ (14)	×	×
1960 mm panel in portrait	ER-TL-10/15	×	×	×	×	×	✓ (7)	×	×	×	×	×	×	×	×	×
	ER-TL-15/30	×	×	×	×	×	×	✓ (9)	×	×	×	×	×	×	×	×
	ER-TL-30/60	×	×	×	✓ (5)	×	×	×	✓ (11)	✓ (13)	×	×	×	✓ (15)	×	×

Note: ✓ indicates applicable; × indicates not applicable

The table above is based on:

- The panels are clamped within one quarter of panel length;
- Rear leg adjustable range: ER-TL-10/15: 260-375 mm; ER-TL-15/30: 390-635 mm; ER-TL-30/60: 675-1205 mm;
- If the info. is different from the table and diagram, it could have different results. Please contact the Clenergy to confirm its applicability.**

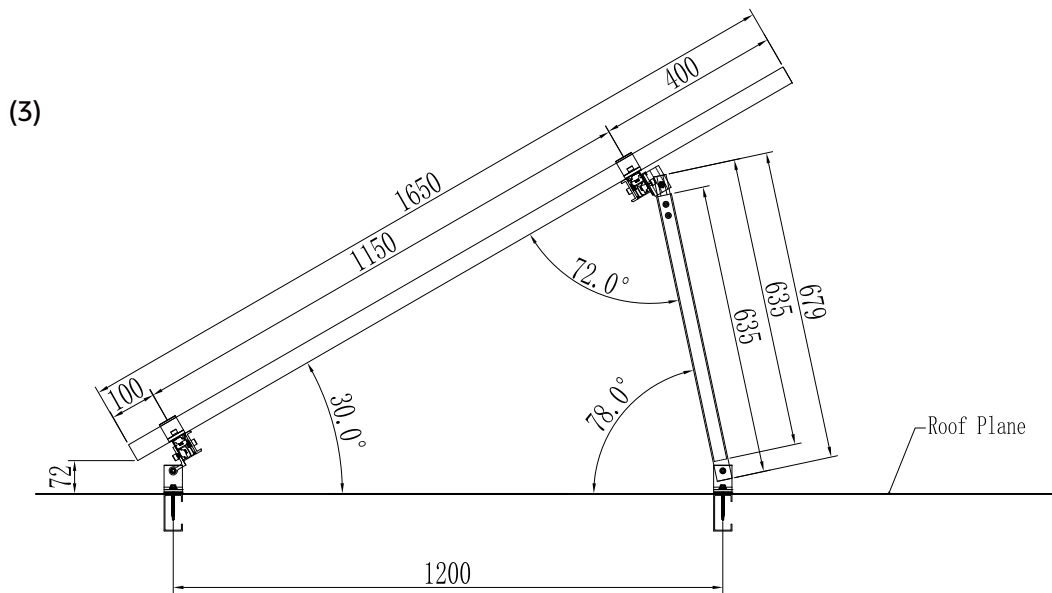
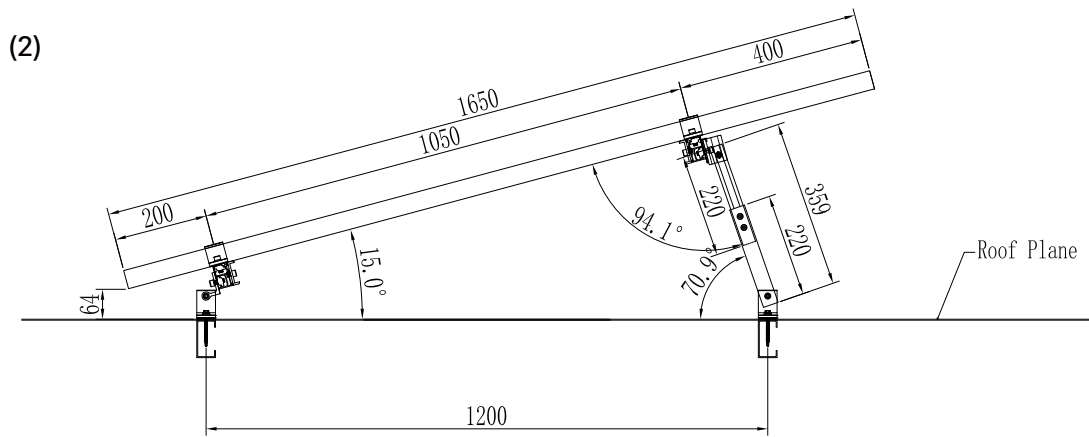
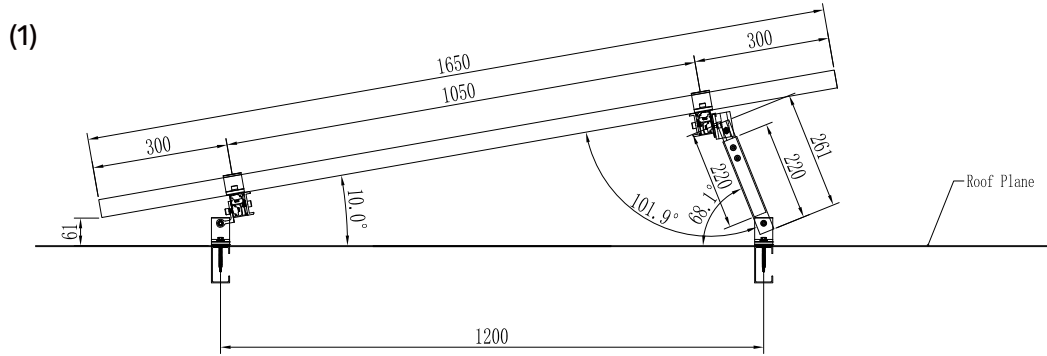

(4)

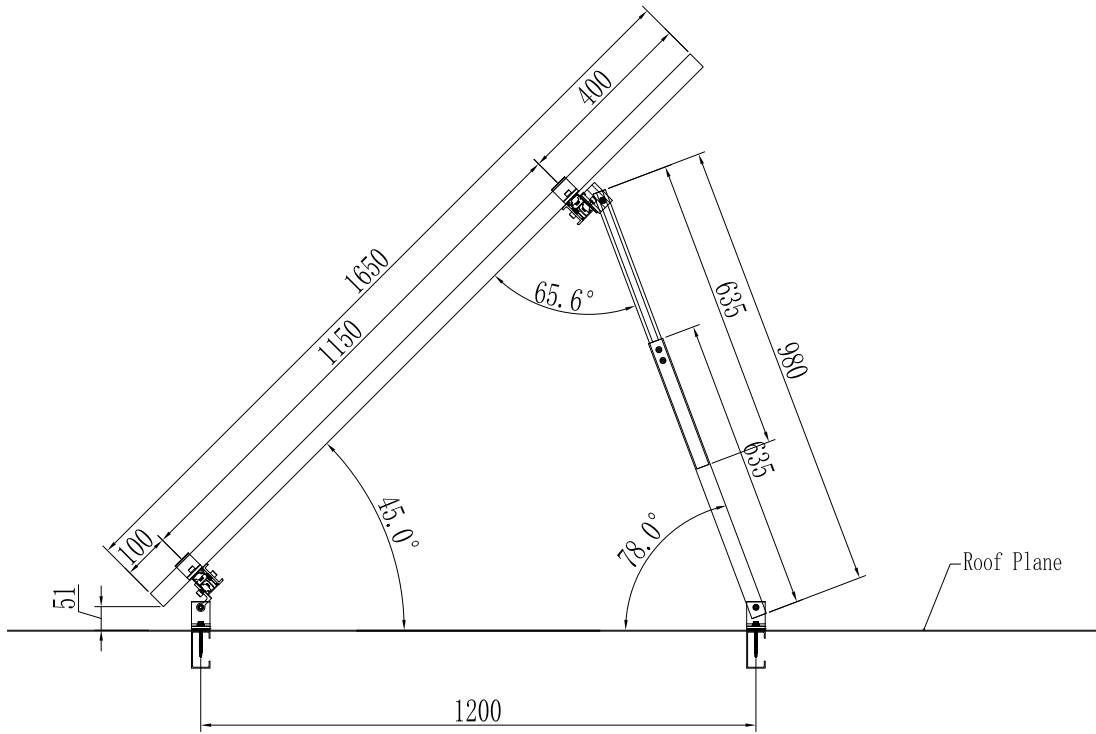

(5)

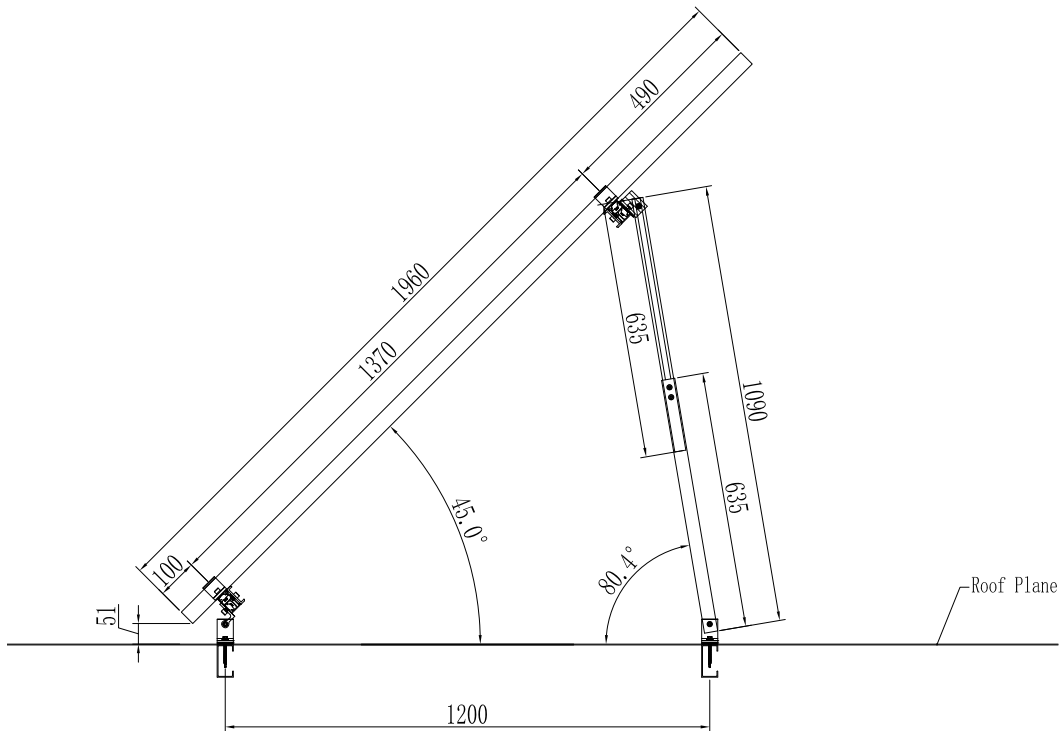

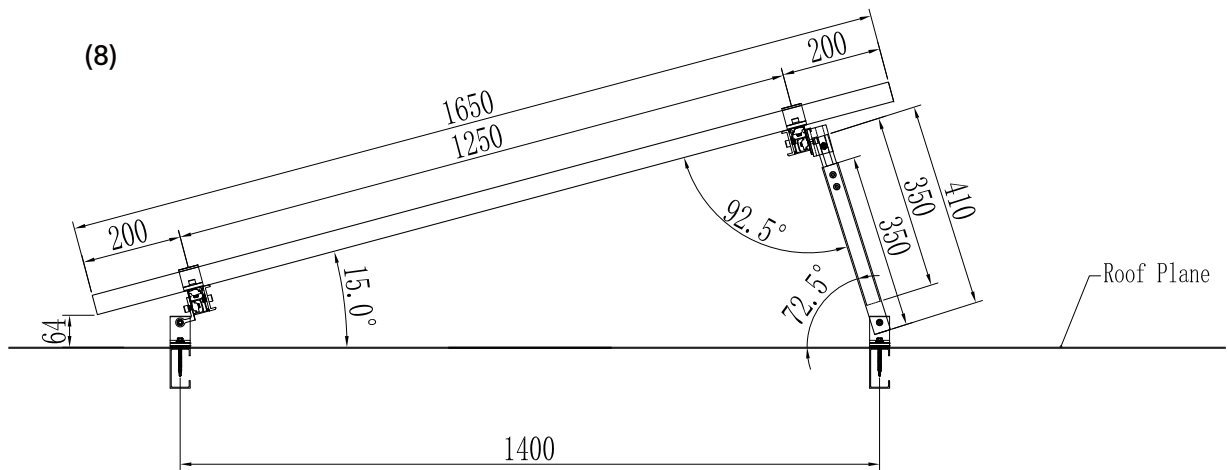
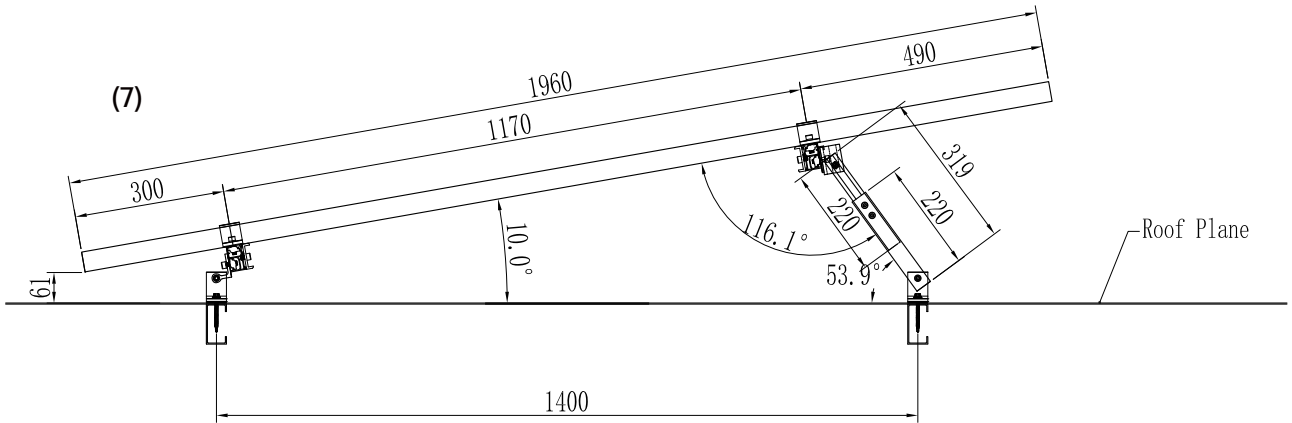
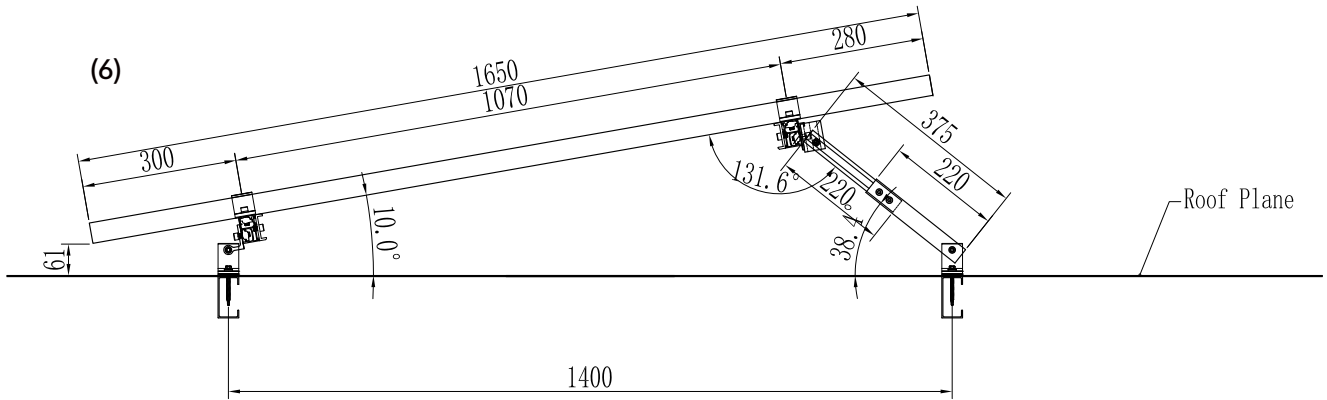

(9)

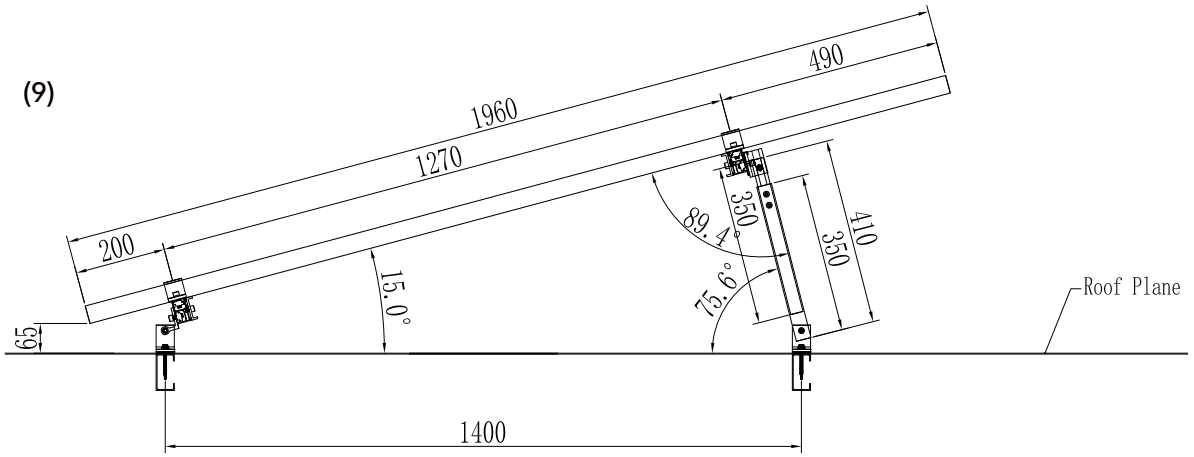

(10)

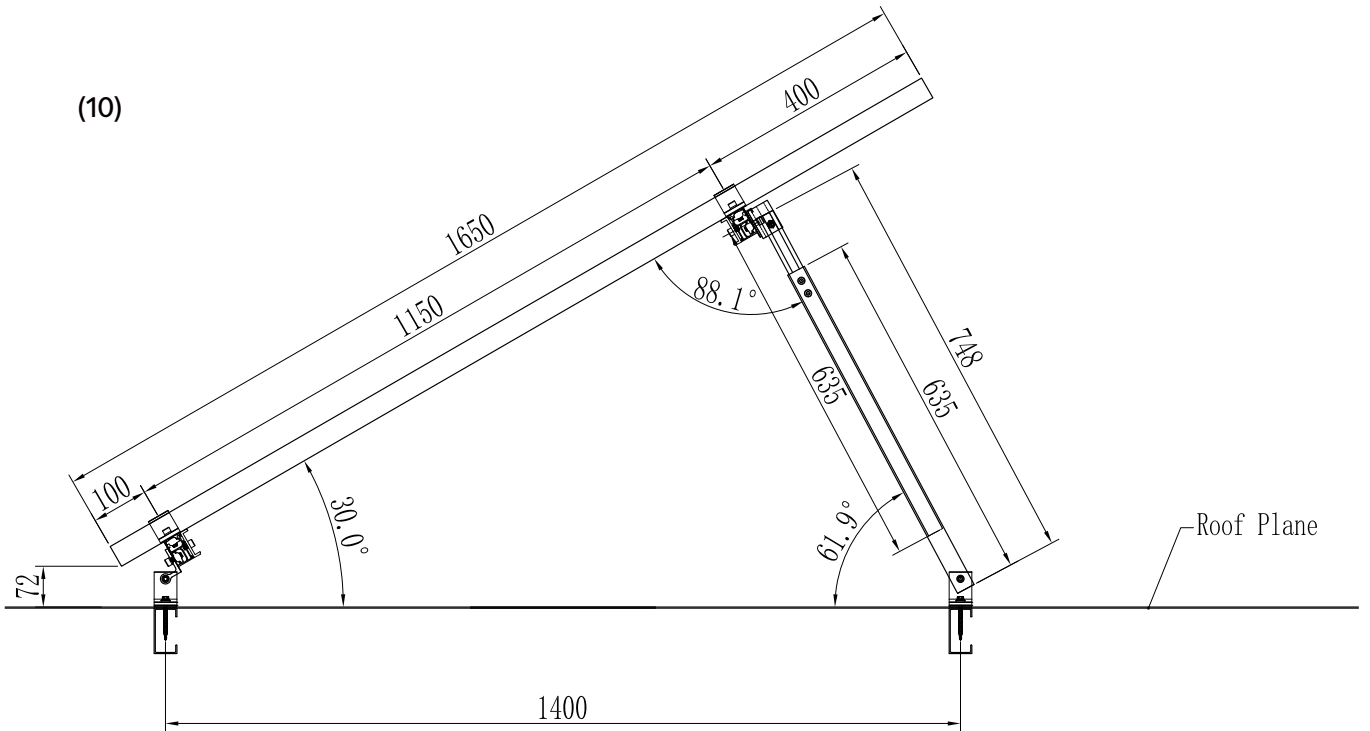

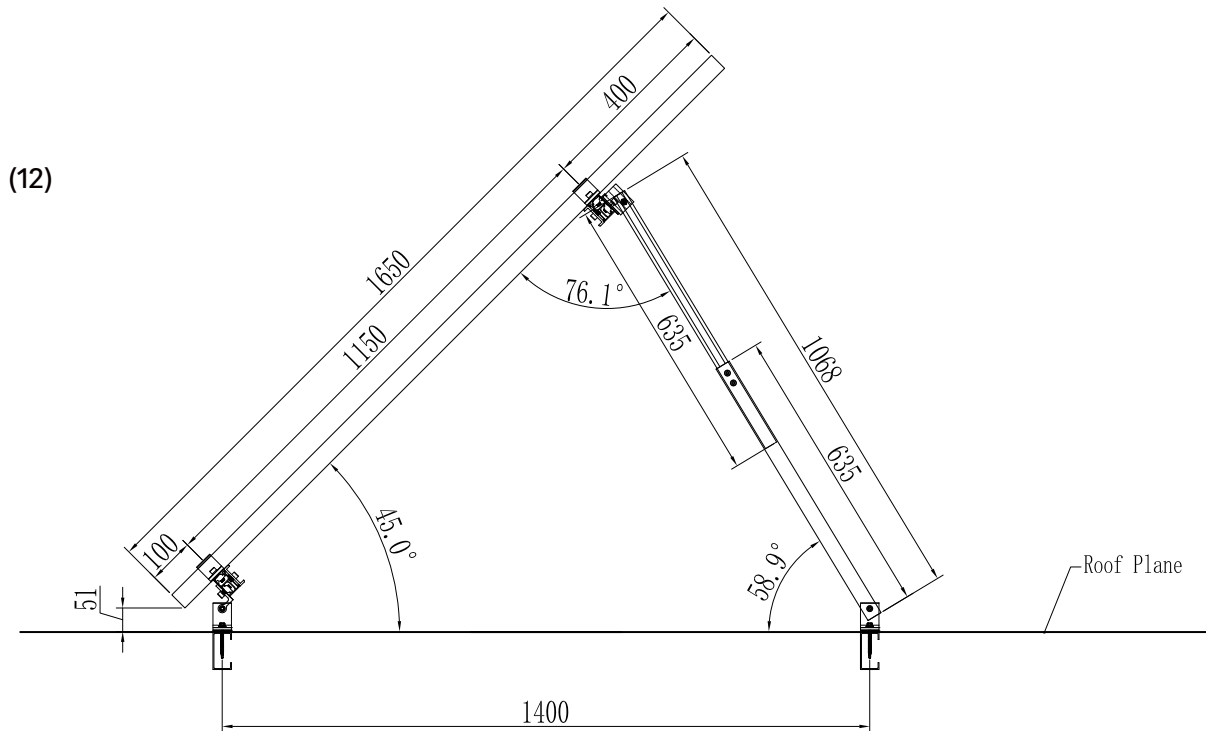
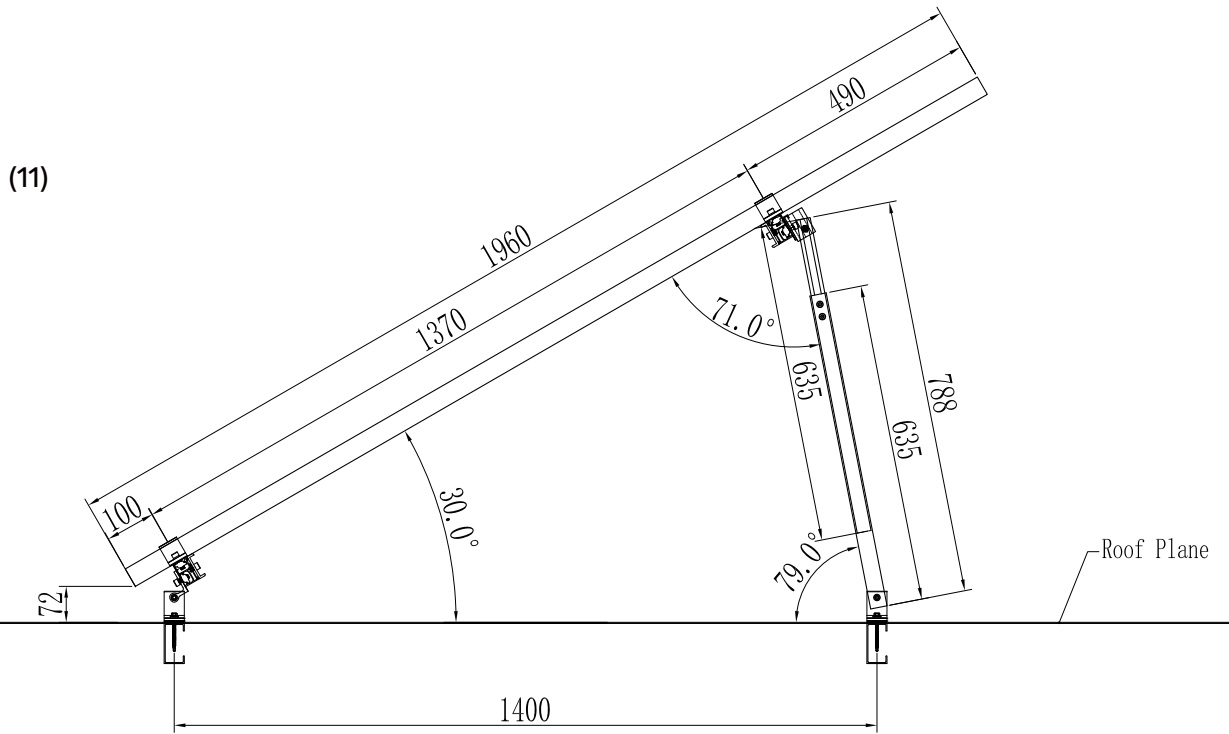

(13)

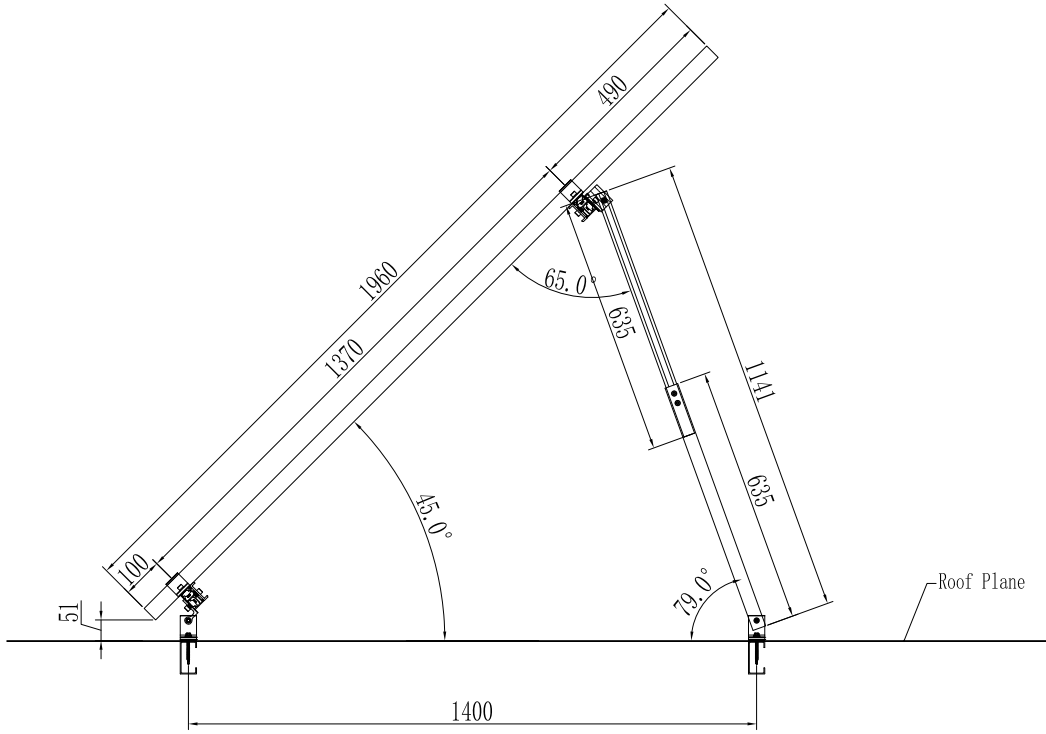

(14)

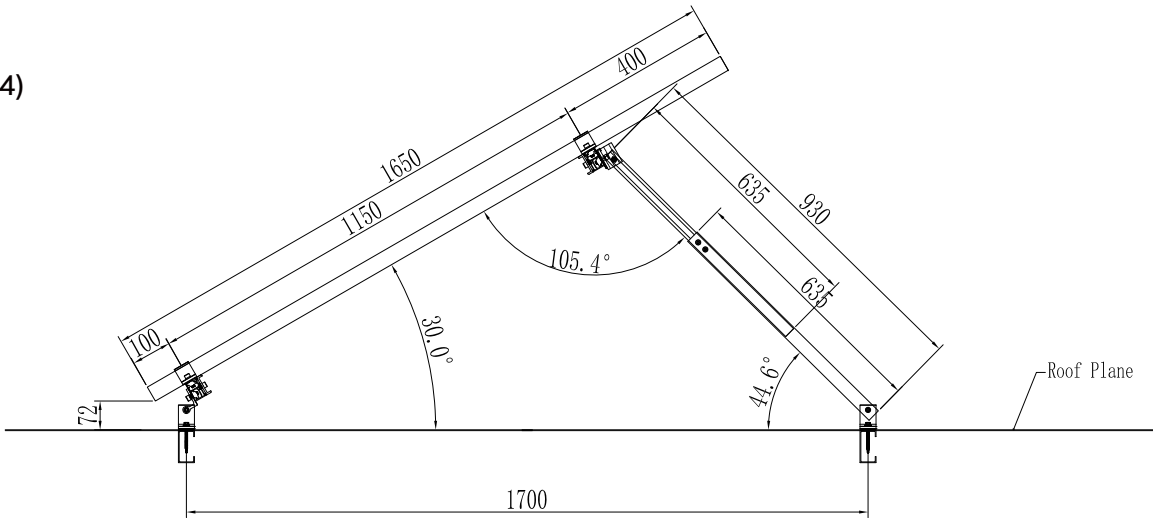



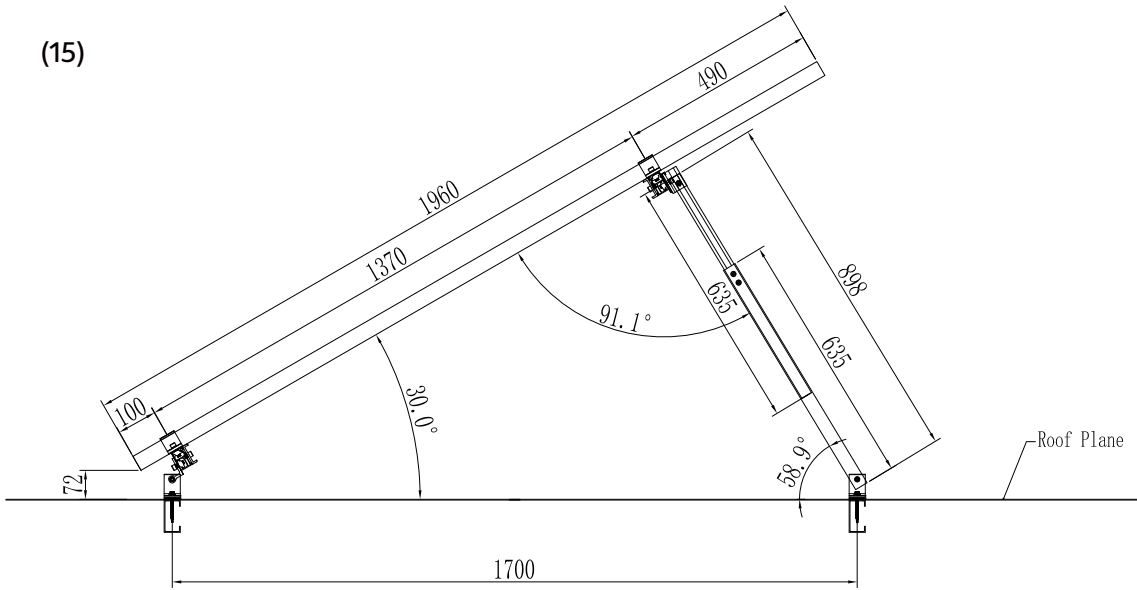

(15)



Tools and Components

Tools

				
Screw Driver (maximum torque ≥ 34N·m)	Torque Spanner	Socket Wrench M8	5m Tape	String & Marker Pen

Components

				
ER-EC-ST End Clamp	ER-IC-ST Inter Clamp	C-U/30/46 Universal Clamp	C-U/30/46-G Universal Clamp	ER-TL-10/15 ER-TL-15/30 ER-TL-30/60 Adjustable Tilt legs, non-preassembly
				
ER-R-ECO ECO-Rail	ER-SP-ECO Splice for ECO-Rail	ER-TL-10/15/PS ER-TL-15/30/PS Adjustable Tilt legs, preassembly	TL-10/15/L/PS TL-15/30/L/PS Adjustable Tilt Legs with L-feet, preassembly	ER-TL-5/PS ER-TL-10/PS Fixed Tilt Legs, preassembly

System Overview

Overview of PV-ezRack® SolarRoof Adjustable Tilt Legs

Adjustable Tilt Legs

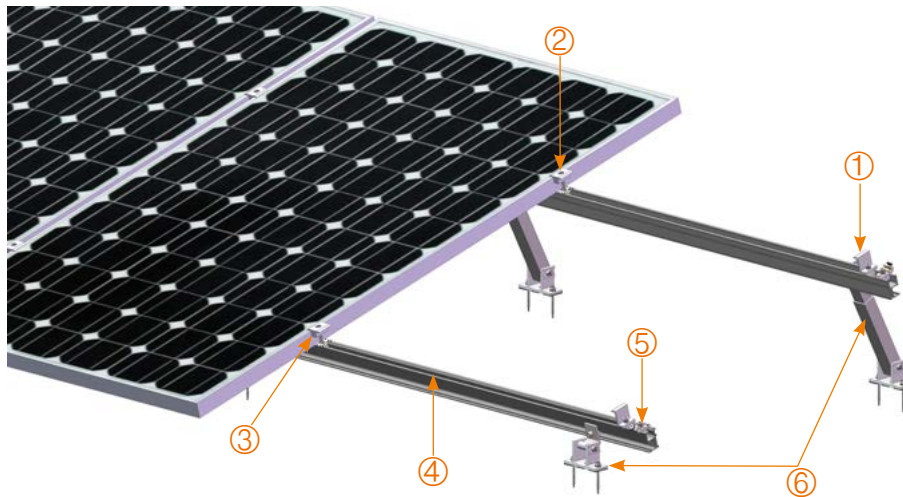

- 1. End Clamp
- 2. Inter Clamp
- 3. Grounding Clip
- 4. ECO-Rail
- 5. Grounding Lug
- 6. Adjustable Tilt Legs

Adjustable Tilt Legs with L-feet

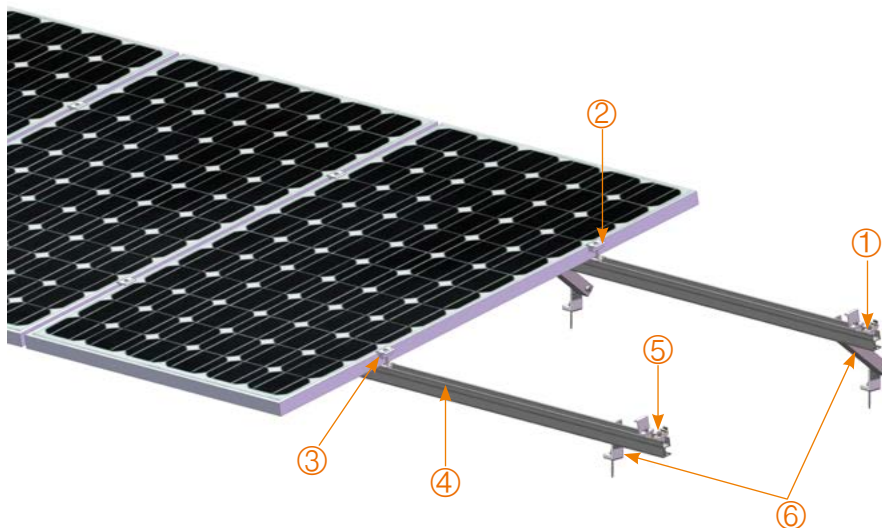

- 1. End Clamp
- 2. Inter Clamp
- 3. Grounding Clip
- 4. ECO-Rail
- 5. Grounding Lug
- 6. Adjustable Tilt Legs with L-feet

Fixed Tilt Legs

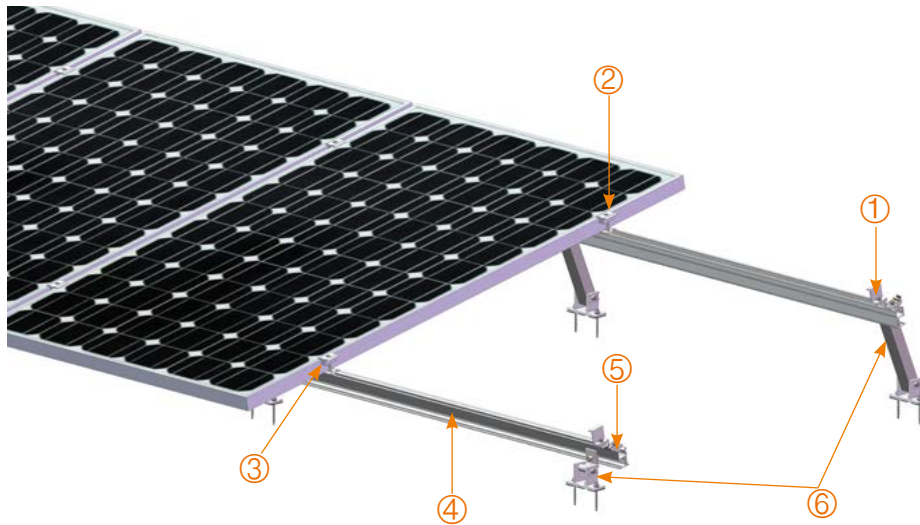

1. End Clamp 2. Inter Clamp 3. Grounding Clip 4. ECO-Rail 5. Grounding Lug 6. Fixed Tilt Legs

Precautions during Stainless Steel Fastener Installation

Improper operation may lead to deadlock of Nuts and Bolts. The steps below should be applied to stainless steel nut and bolt assembly to reduce this risk.

General installation instructions:

- (1) Apply force to fasteners in the direction of thread
- (2) Apply force uniformly, to maintain the required torque
- (3) Professional tools and tool belts are recommended
- (4) In some cases, fasteners could be seized over time. As an option, if want to avoid galling or seizing of thread, apply lubricant (grease or 40# engine oil) to fasteners prior to tightening.

Safe Torques

Please refer to safe torques defined in this guide as shown in the figure below. If power tools are required, Clenergy recommends the use of low speed only. High speed and impact drivers increase the risk of bolt galling (deadlock). If deadlock occurs and you need to cut fasteners, please make sure that there is no load on the fastener before you cut it. Avoid damaging the anodized or galvanized surfaces.

1) Adjustable Tilt Legs

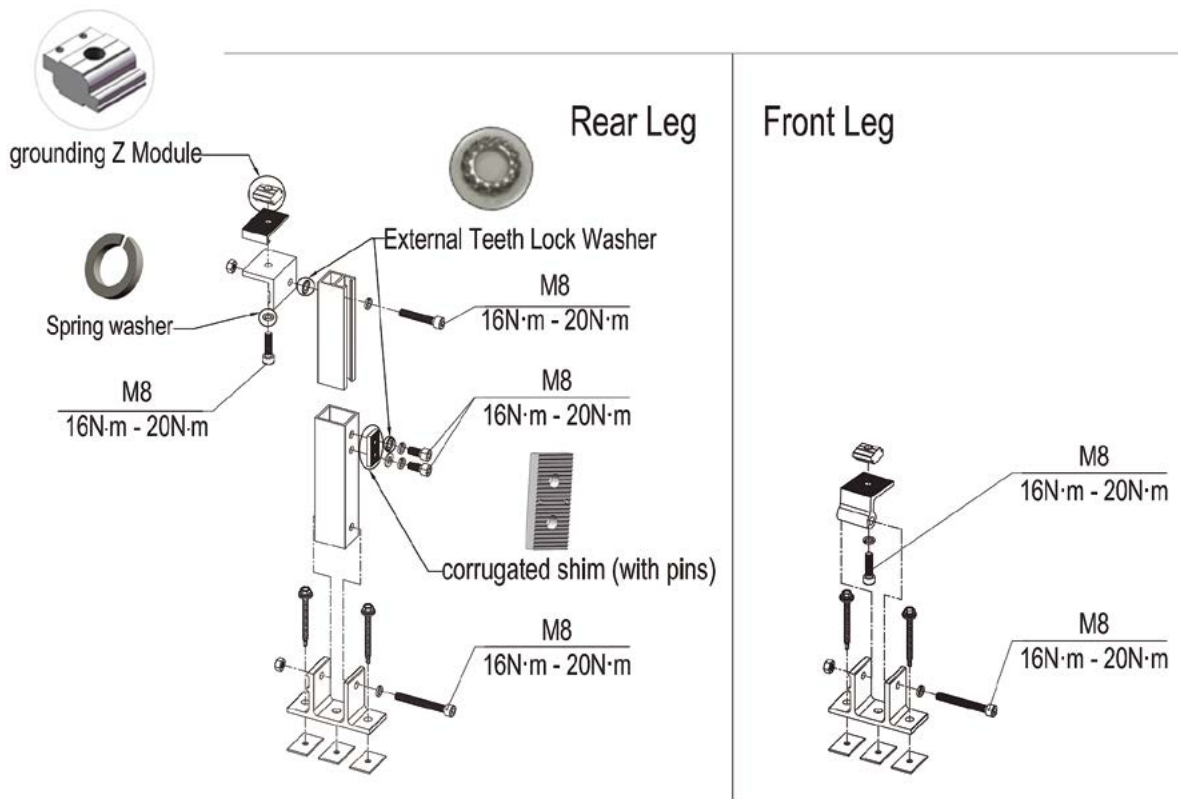

Note:

Grounding Z Module, External Teeth Lock Washers, Spring washer and corrugated shim (with pins) on the diagram above are to create the electrical continuity between rail and rear leg tubes.

2) Adjustable Tilt Legs with L-feet

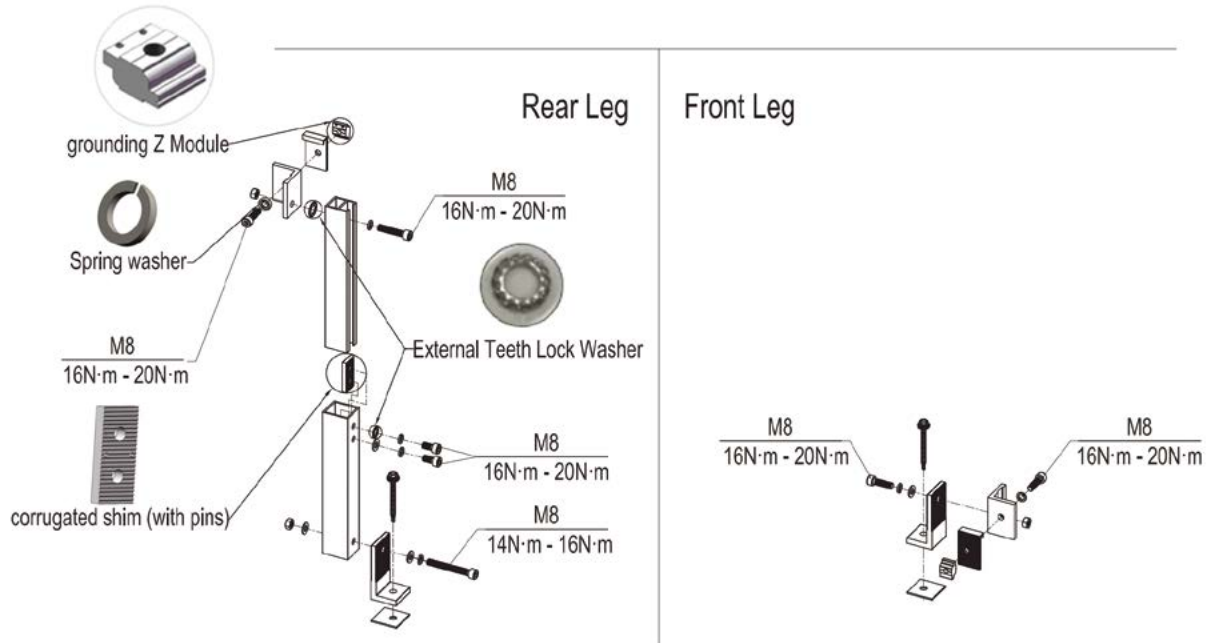

Note:

Grounding Z Module, External Teeth Lock Washers, Spring washer and corrugated shim (with pins) on the diagram above are to create the electrical continuity between rail and rear leg tubes.

3) Fixed Tilt Legs

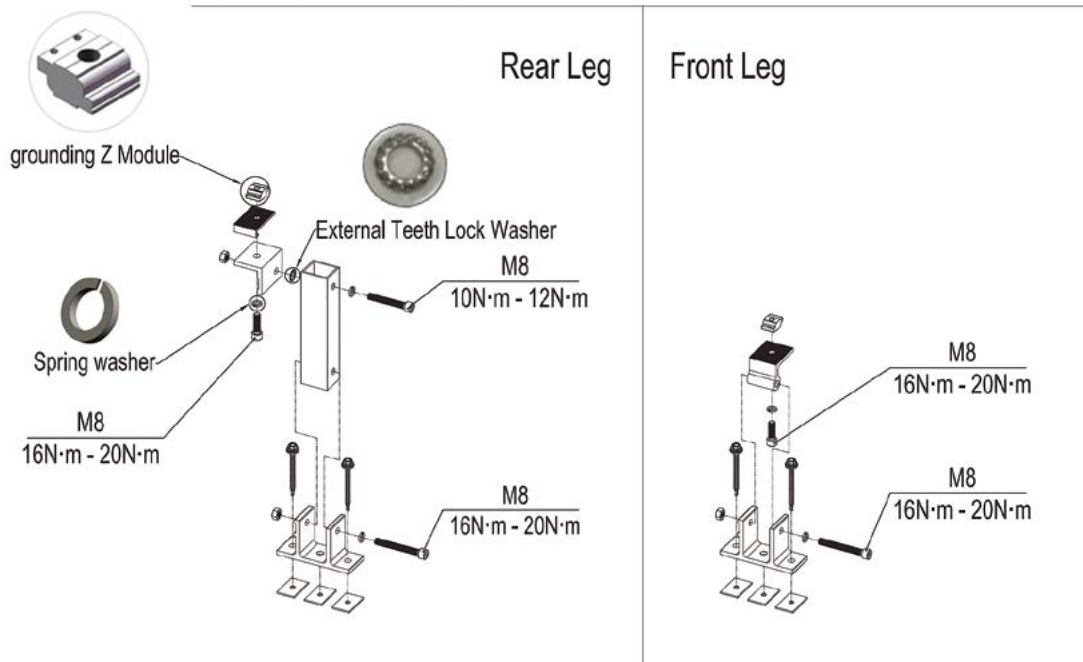

Note:

Grounding Z Module, External Teeth Lock Washer and Spring washer on the diagram above are to create the electrical continuity between rail and rear leg tubes.

Installation Instructions

Front & Rear Leg Installation

Front Leg Installation

According to the installation plan, determine the mounting position and direction of the front legs. Either two screws or single screw (Buildex 14-11 x 70 Hex Head Zips screw) is required depending on the installation spacing requirement. See two screws and single screw options in Figures 1 and 2. Tin foot front leg installation is in Figure 3.

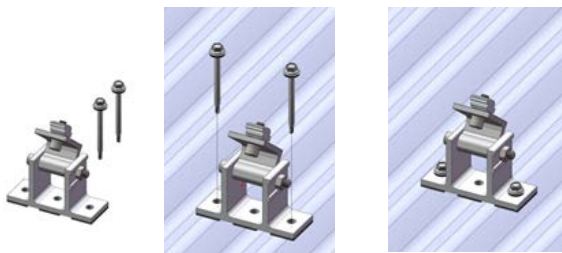

Figure 1
(Front Leg Installation with Two Screws)

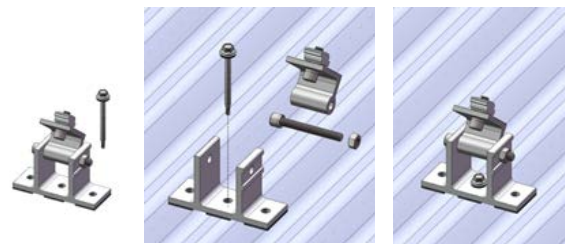

Figure 2
(Front Leg Installation with Single Screw)

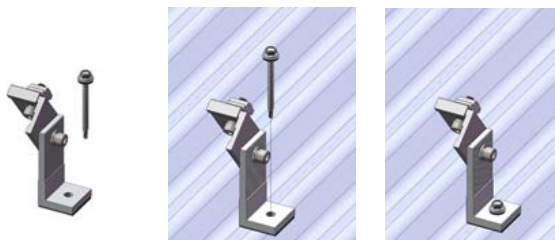
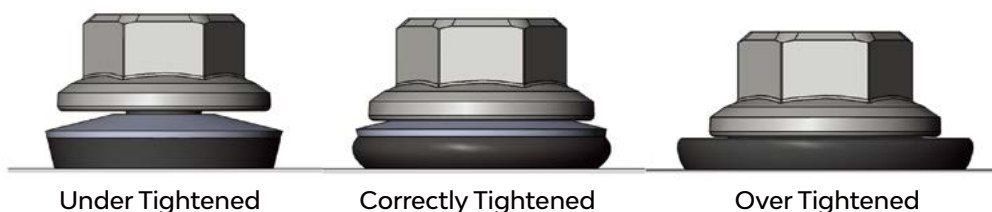

Figure 3
(Tin Foot Front Leg Installation)

Please follow Buildex screws installation guide below:

- Use a 3/8" Hex Socket.
- Use a mains powered or cordless screw driver with a drive speed of 3,000 RPM maximum.
- Fit the driver bit into the screw and place at the fastening position.
- Apply consistently firm pressure (end load) to the screw driver until the screw is fastened.
- Screws with bonded washers should be tightened only until the washer is gripped firmly enough to provide a watertight seal. The screws should be neither under tightened nor over tightened to lead to water penetration. Take particular care to ensure the screw is driven perpendicular to the interface to avoid deformation of the washer.



Rear Leg Installation

According to the installation plan, after confirming the length L of the Rear Leg, fasten two M8*12 bolts as shown in Figure 4.

Recommended torque for M8*12 bolts is 18~20 N·m

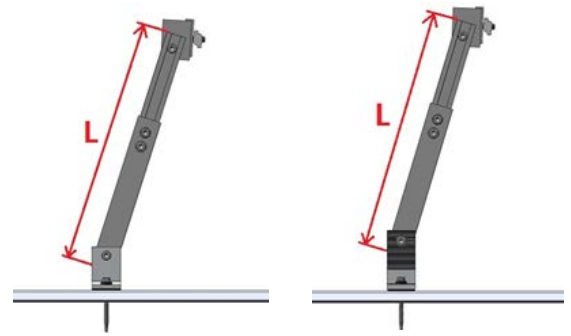

Figure 4

According to the installation plan, either two screws or single screw (Buildex 14-11 x 70 Hex Head Zips screw) is used to install rear leg. Using preassembly or non-preassembly rear legs will make installation steps a bit different as well. See the installation images in Figures 5-9.

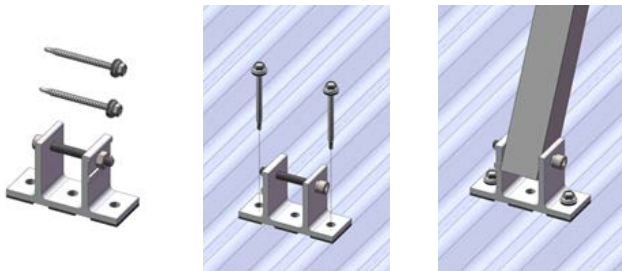

Figure 5

(Non-preassembly Rear Leg Installation with Two Screws)

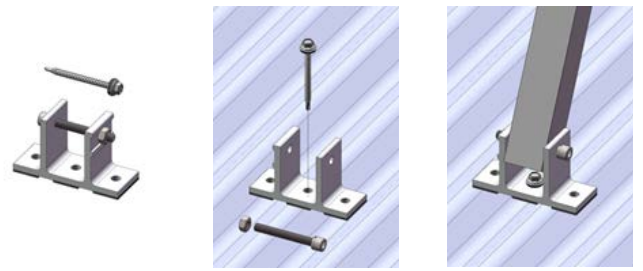

Figure 6

(Non-preassembly Rear Leg Installation with Single Screw)



Figure 7

(Preassembly Rear Leg Installation with Two Screws)



Figure 8

(Preassembly Rear Leg Installation with Single Screw)



Figure 9

(Tin Foot Rear Leg Installation)

Install the remaining Front and Rear Legs in Figure 10.

NOTE:

WHEN USING TIN INTERFACES FOR INSTALLATION WORKS, SCREWS NOT EXPOSED TO FREQUENT RAIN SHOULD BE WASHED DOWN WITH FRESH WATER AT LEAST EVERY 6 MONTHS TO MEET THE WARRANTY CONDITIONS OF BUILDEX SCREWS.

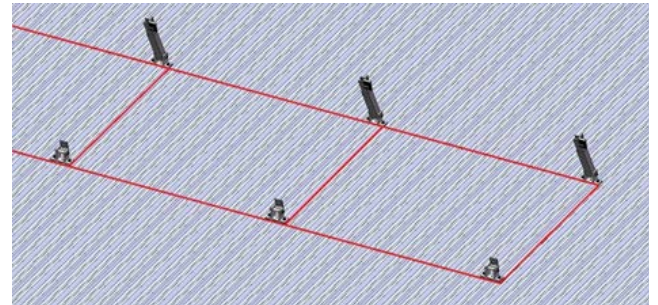

Figure 10

Rail Installation

According to the installation plan, determine the mounting position of Rail.

To connect several Rails together, slide half of the splice into the rear side of the Rail. Fasten the first M8 Bolt using an Allen key, and slide the next Rail into the Splice as shown in Figure 11 and 12. Tighten the second M8 Bolt using an Allen key. Splice provides the electrical connection between the 2 rails through the pressure bolts. This eliminates the need of using 2 earthing lugs.

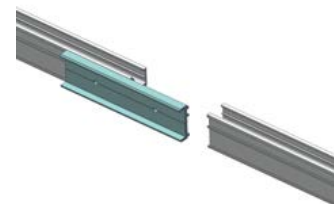

Figure 11

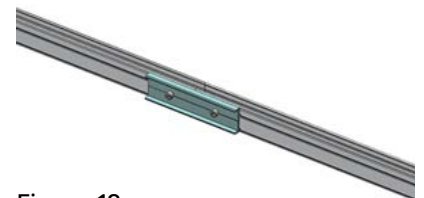

Figure 12

Recommended torque for M8 bolts is 10~12 N·m

After confirming the position of Rail, fasten the Front and Rear Leg, as shown in Figure 13, 14 and 15.

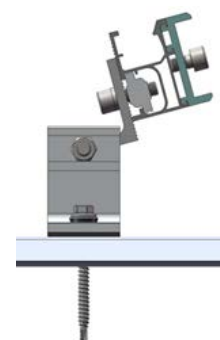

Figure 13

Recommended torque for M8 bolts is 18~20 N·m

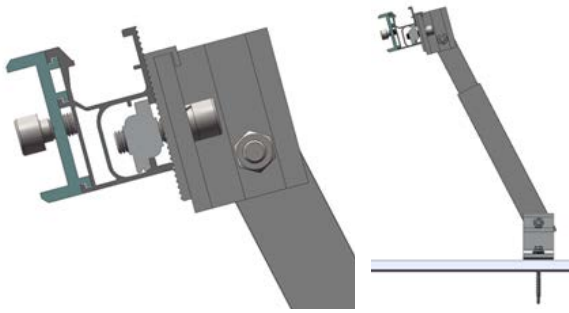

Figure 14

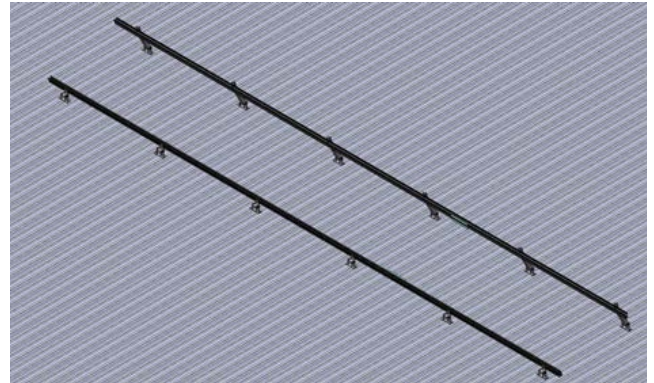

Figure 15

PV Module Installation

- 1) Please refer [PV-ezRack® Grounding System](#) for PV modules clamps and grounding lugs installations.
- 2) The installers must ensure panel clamps are installed flush mounted to the panel frame and apply correct torque value of clamp fastener as shown in section "Safe Torques (P17)".

Certification



CIVIL & STRUCTURAL ENGINEERS
 RESIDENTIAL - INDUSTRIAL - COMMERCIAL - PRODUCT DEVELOPMENT
 info@mwengineering.melbourne
 Phone: 1300 MWENG-0 (1300 69364-0)
 www.mwengineering.melbourne
 ABN 37 605 815 585

05 October 2021

Clenergy Australia
 1/10 Duerdin Street
 Clayton, VIC 3168

CERTIFICATION LETTER

Clenergy PV ez-Rack penetrative tilt Certification – TC2, 2.5, 3 – Wind Region A, B, C, D. Project No.: **CL-530-S-REV1**. Internal REF: **00400**.

MW Engineering Melbourne, being Structural Engineers within the meaning of Australian regulations, have calculated the maximum spacings for the PV ez-Rack rail system for the following conditions:

- **Wind Loads to AS 1170.2-2011 AMDT 4-2016**
 - o **Wind Terrain Category 2, 2.5 and 3**
 - o **Wind average recurrence of 200 years**
 - o **Wind Region A, B, C and D**
- **Solar panel length up to 2.4 m**

Attached are the tables showing the spacings according to Wind Region, roof pitch, and building height.

The values shown on these tables will be valid unless an amendment is issued on any of the following codes:

- | | |
|-----------------------------------|---------------------------|
| - AS/NZS 1170.0- 2002 AMDT 4-2016 | General Principles |
| - AS/NZS 1170.1- 2002 AMDT 4-2016 | Imposed Loadings |
| - AS/NZS 1170.2- 2011 AMDT 4-2016 | Wind Loadings |
| - AS/NZS 1664.1- 1997 AMDT 1:1999 | Aluminium Code |

Should you have any queries, do not hesitate to contact us.

Best Regards,

Alberto Escobar
 Civil/Structural Engineer
BEng MIEAust NER
 PE0003615
 RPEQ 18759
info@mwengineering.melbourne

October 2021



STRUCTURAL DESIGN CERTIFICATION

PV-ezRack® SolarRoof penetrative tilt interface spacing tables according to AS/NZS 1170.2:2011 Amdt 4-2016 Within Australia Terrain Category 2, 2.5 & 3

Client: Clenergy Australia

REF: 00400

Date: OCT 2021

Copyright: The concepts and information contained in this document are the property of MW Engineering Melbourne. Use or copying of this document in whole or in part without the written permission of MW Engineering Melbourne constitutes an infringement in copyright.

Limitation: This report has been prepared for the exclusive use of Clenergy Australia and is subject to and issued in connection with the provisions of the agreement between MW Engineering Melbourne and Clenergy Australia. MW Engineering Melbourne accepts no liability or responsibility whatsoever for any use of or reliance upon this report by any third party other than Clenergy's clients.



REF: 00400

Client: Clenergy Australia

Internal reference: CL-530-S-REV1

Project: PV ez-Rack SolarRoof penetrative tilt interface spacing tables

Australian Standards

AS/NZS 1170.0:2002 (R2016)

General Principles

AS/NZS 1170.1:2002 (R2016)

Imposed loadings

AS/NZS 1170.2:2011 (R2016)

Wind Loadings

AS/NZS 1664.1:1997-Amdt 1:1999

Aluminium

Wind Terrain Category: 2, 2.5 & 3

Wind average recurrence: 200 years

Designed: SM

Date: OCT 2021

Disclaimer: From the date of publication onwards, any amendment made to any of the above-mentioned Standards will make this report outdated and a new one will have to be released, unless the amendment has no implications on this certificate.

Contents

Terrain Category 2 – Fixing spacings 4
Terrain Category 2.5 – Fixing spacings 7
Terrain Category 3 – Fixing spacings 10
General Notes 13

PV ez-Rack SolarRoof Interface spacing table for penetrative tilt legs

Type of Rail ER-R-ECO (see [Note 12](#) for other compatible rails)
 Solar Panel Dimension 2 m x 1 m (see [Note 25](#) for other panel sizes)
 Terrain Category 2

Angle against horizontal <math>\alpha < 10^\circ</math>

Wind Region	Building Height (m)																			
	H ≤ 5				5 < H ≤ 10				10 < H ≤ 15				15 < H ≤ 20				20 < H ≤ 30			
	Corner	Edge	Intermediate	Internal	Corner	Edge	Intermediate	Internal	Corner	Edge	Intermediate	Internal	Corner	Edge	Intermediate	Internal	Corner	Edge	Intermediate	Internal
A	712	1079	1425	1781	648	982	1297	1621	627	950	1254	1567	524	793	1047	1309	421	631	842	1262
B	529	802	1059	1540	498	754	995	1244	487	738	974	1218	413	626	826	1032	310	465	619	929
C	460	697	921	1151	379	574	758	947	363	550	726	908	266	403	533	666	194	292	389	583
D	354	536	708	885	319	483	637	797	226	342	451	564	212	322	425	531	155	232	310	465

Angle against horizontal - $10^\circ \leq \alpha < 15^\circ$

Wind Region	Building Height (m)																			
	H ≤ 5				5 < H ≤ 10				10 < H ≤ 15				15 < H ≤ 20				20 < H ≤ 30			
	Corner	Edge	Intermediate	Internal	Corner	Edge	Intermediate	Internal	Corner	Edge	Intermediate	Internal	Corner	Edge	Intermediate	Internal	Corner	Edge	Intermediate	Internal
A	648	982	1297	1588	583	884	1167	1459	545	825	1089	1361	459	696	919	1149	355	532	709	1064
B	461	698	922	1152	392	593	783	979	332	503	664	829	323	490	647	809	226	339	453	679
C	408	619	817	1021	290	440	580	726	219	333	439	549	188	286	377	471	122	183	243	365
D	331	502	663	828	225	341	451	563	129	196	258	323	149	226	298	373	100	149	199	299

Angle against horizontal - $15^\circ \leq \alpha < 20^\circ$

Wind Region	Building Height (m)																			
	H ≤ 5				5 < H ≤ 10				10 < H ≤ 15				15 < H ≤ 20				20 < H ≤ 30			
	Corner	Edge	Intermediate	Internal	Corner	Edge	Intermediate	Internal	Corner	Edge	Intermediate	Internal	Corner	Edge	Intermediate	Internal	Corner	Edge	Intermediate	Internal
A	613	928	1225	1501	502	761	1005	1256	490	743	980	1225	434	658	868	1086	335	503	670	1005
B	416	630	831	1039	312	472	623	779	291	441	582	727	245	371	490	612	180	270	360	540
C	381	577	762	953	248	375	495	619	218	330	436	545	161	244	322	402	103	155	206	310
D	309	468	618	772	232	351	463	579	162	246	324	405	139	211	278	347	91	136	181	272

PV ez-Rack SolarRoof Interface spacing table for penetrative tilt legs (Cont.)

Type of Rail ER-R-ECO (see [Note 12](#) for other compatible rails)
 Solar Panel Dimension 2 m x 1 m (see [Note 25](#) for other panel sizes)
 Terrain Category 2

Angle against horizontal - $20^\circ \leq \alpha < 25^\circ$

Wind Region	Building Height (m)																			
	H ≤ 5				5 < H ≤ 10				10 < H ≤ 15				15 < H ≤ 20				20 < H ≤ 30			
	Corner	Edge	Intermediate	Internal	Corner	Edge	Intermediate	Internal	Corner	Edge	Intermediate	Internal	Corner	Edge	Intermediate	Internal	Corner	Edge	Intermediate	Internal
A	538	822	1075	1398	441	674	882	1146	430	658	860	1118	362	554	725	942	290	434	579	869
B	360	551	721	937	270	413	541	703	252	386	505	656	203	311	406	528	149	223	298	447
C	334	511	669	869	217	332	435	565	203	310	406	527	135	206	270	350	94	141	188	283
D	271	414	542	705	203	311	407	528	142	218	285	370	132	202	264	344	79	119	159	238

Angle against horizontal - $25^\circ \leq \alpha < 30^\circ$

Wind Region	Building Height (m)																			
	H ≤ 5				5 < H ≤ 10				10 < H ≤ 15				15 < H ≤ 20				20 < H ≤ 30			
	Corner	Edge	Intermediate	Internal	Corner	Edge	Intermediate	Internal	Corner	Edge	Intermediate	Internal	Corner	Edge	Intermediate	Internal	Corner	Edge	Intermediate	Internal
A	500	765	1000	1300	410	627	820	1066	400	612	800	1040	333	509	665	865	269	404	538	808
B	327	500	654	851	229	350	458	595	229	350	458	595	184	282	369	479	147	221	295	442
C	303	463	606	788	197	301	394	512	184	281	368	478	122	187	244	317	92	138	184	276
D	238	364	476	619	179	273	357	464	125	191	250	325	107	164	214	278	76	114	152	227

Angle against horizontal - $\alpha = 30^\circ$

Wind Region	Building Height (m)																			
	H ≤ 5				5 < H ≤ 10				10 < H ≤ 15				15 < H ≤ 20				20 < H ≤ 30			
	Corner	Edge	Intermediate	Internal	Corner	Edge	Intermediate	Internal	Corner	Edge	Intermediate	Internal	Corner	Edge	Intermediate	Internal	Corner	Edge	Intermediate	Internal
A	449	686	897	1167	368	563	736	957	359	549	718	933	283	432	565	735	225	337	449	674
B	294	449	587	763	205	314	411	534	200	305	399	519	165	253	331	430	117	175	234	351
C	272	416	544	707	167	256	334	435	165	252	330	429	117	178	233	303	73	110	147	220
D	210	322	421	547	160	245	320	416	115	176	230	300	103	157	205	267	59	88	118	176

PV ez-Rack SolarRoof Interface spacing table for penetrative tilt legs (Cont.)

Type of Rail ER-R-ECO (see [Note 12](#) for other compatible rails)
 Solar Panel Dimension 2 m x 1 m (see [Note 25](#) for other panel sizes)
 Terrain Category 2

Angle against horizontal - $30^\circ < \alpha \leq 60^\circ$

Wind Region	Building Height (m)																			
	H ≤ 5				5 < H ≤ 10				10 < H ≤ 15				15 < H ≤ 20				20 < H ≤ 30			
	Corner	Edge	Intermediate	Internal	Corner	Edge	Intermediate	Internal	Corner	Edge	Intermediate	Internal	Corner	Edge	Intermediate	Internal	Corner	Edge	Intermediate	Internal
A	677	978	1173	1354	609	932	1131	1267	569	924	1056	1232	509	780	975	1170	303	454	606	909
B	431	658	894	1088	389	640	907	1088	371	577	799	1038	293	439	585	878	210	314	419	629
C	308	462	616	924	266	398	531	797	262	392	523	785	196	294	392	589	112	168	224	336
D	218	326	435	653	211	317	422	633	160	240	320	480	153	230	307	460	90	135	180	269

PV ez-Rack SolarRoof Interface spacing table for penetrative tilt legs

Type of Rail ER-R-ECO (see [Note 12](#) for other compatible rails)
 Solar Panel Dimension 2 m x 1 m (see [Note 25](#) for other panel sizes)
 Terrain Category 2.5

Angle against horizontal <math>< 10^\circ</math>

Wind Region	Building Height (m)																			
	$H \leq 5$				$5 < H \leq 10$				$10 < H \leq 15$				$15 < H \leq 20$				$20 < H \leq 30$			
	Corner	Edge	Intermediate	Internal	Corner	Edge	Intermediate	Internal	Corner	Edge	Intermediate	Internal	Corner	Edge	Intermediate	Internal	Corner	Edge	Intermediate	Internal
A	731	1108	1463	1829	666	1008	1331	1664	644	975	1287	1609	538	815	1075	1344	432	648	864	1296
B	544	823	1087	1581	511	774	1022	1277	500	758	1000	1250	424	642	848	1060	318	477	636	954
C	473	716	945	1182	389	590	778	973	373	565	745	932	273	414	547	684	200	300	399	599
D	364	551	727	909	327	496	654	818	232	351	463	579	218	330	436	545	159	239	318	477

Angle against horizontal - $10^\circ \leq \alpha < 15^\circ$

Wind Region	Building Height (m)																			
	$H \leq 5$				$5 < H \leq 10$				$10 < H \leq 15$				$15 < H \leq 20$				$20 < H \leq 30$			
	Corner	Edge	Intermediate	Internal	Corner	Edge	Intermediate	Internal	Corner	Edge	Intermediate	Internal	Corner	Edge	Intermediate	Internal	Corner	Edge	Intermediate	Internal
A	666	1008	1331	1631	599	908	1198	1498	559	847	1118	1398	472	715	943	1179	364	546	728	1092
B	473	717	946	1183	402	609	804	1005	341	516	681	852	332	503	664	830	232	349	465	697
C	419	635	839	1048	298	452	596	745	225	341	451	563	194	293	387	484	125	187	250	375
D	340	515	680	850	231	350	463	578	133	201	265	332	153	232	306	383	102	153	204	307

Angle against horizontal - $15^\circ \leq \alpha < 20^\circ$

Wind Region	Building Height (m)																			
	$H \leq 5$				$5 < H \leq 10$				$10 < H \leq 15$				$15 < H \leq 20$				$20 < H \leq 30$			
	Corner	Edge	Intermediate	Internal	Corner	Edge	Intermediate	Internal	Corner	Edge	Intermediate	Internal	Corner	Edge	Intermediate	Internal	Corner	Edge	Intermediate	Internal
A	629	953	1258	1541	516	782	1032	1290	503	762	1006	1258	446	675	892	1115	344	516	688	1032
B	427	647	854	1067	320	485	640	800	299	453	597	747	252	381	503	629	185	277	370	555
C	391	593	782	978	254	385	509	636	224	339	448	559	165	250	331	413	106	159	212	318
D	317	480	634	793	238	360	476	594	166	252	333	416	143	216	285	357	93	140	186	279

PV ez-Rack SolarRoof Interface spacing table for penetrative tilt legs (Cont.)

Type of Rail ER-R-ECO (see [Note 12](#) for other compatible rails)
 Solar Panel Dimension 2 m x 1 m (see [Note 25](#) for other panel sizes)
 Terrain Category 2.5

Angle against horizontal - $20^\circ \leq \alpha < 25^\circ$

Wind Region	Building Height (m)																			
	H ≤ 5				5 < H ≤ 10				10 < H ≤ 15				15 < H ≤ 20				20 < H ≤ 30			
	Corner	Edge	Intermediate	Internal	Corner	Edge	Intermediate	Internal	Corner	Edge	Intermediate	Internal	Corner	Edge	Intermediate	Internal	Corner	Edge	Intermediate	Internal
A	552	844	1104	1435	453	692	905	1177	442	675	883	1148	372	569	744	967	297	446	595	892
B	370	566	740	962	278	425	555	722	259	396	518	674	208	319	417	542	153	229	306	459
C	343	525	687	893	223	341	446	580	208	319	417	542	138	212	277	360	97	145	193	290
D	278	426	557	723	209	319	417	543	146	223	292	380	136	207	271	353	81	122	163	244

Angle against horizontal - $25^\circ \leq \alpha < 30^\circ$

Wind Region	Building Height (m)																			
	H ≤ 5				5 < H ≤ 10				10 < H ≤ 15				15 < H ≤ 20				20 < H ≤ 30			
	Corner	Edge	Intermediate	Internal	Corner	Edge	Intermediate	Internal	Corner	Edge	Intermediate	Internal	Corner	Edge	Intermediate	Internal	Corner	Edge	Intermediate	Internal
A	513	785	1027	1335	421	644	842	1095	411	628	821	1068	341	522	683	888	276	415	553	829
B	336	514	672	873	235	360	470	611	235	360	470	611	189	289	378	492	151	227	303	454
C	311	476	622	809	202	309	404	526	189	289	377	491	125	192	251	326	95	142	189	284
D	244	374	489	635	183	280	367	477	128	196	257	334	110	168	220	286	78	117	156	234

Angle against horizontal - $\alpha = 30^\circ$

Wind Region	Building Height (m)																			
	H ≤ 5				5 < H ≤ 10				10 < H ≤ 15				15 < H ≤ 20				20 < H ≤ 30			
	Corner	Edge	Intermediate	Internal	Corner	Edge	Intermediate	Internal	Corner	Edge	Intermediate	Internal	Corner	Edge	Intermediate	Internal	Corner	Edge	Intermediate	Internal
A	461	705	921	1198	378	578	755	982	369	564	737	958	290	444	580	755	231	346	461	692
B	301	461	603	784	211	323	422	549	205	313	410	533	170	260	340	441	120	180	240	360
C	279	427	558	726	172	263	343	446	169	259	339	440	120	183	239	311	75	113	151	226
D	216	330	432	562	164	251	328	427	118	181	237	308	105	161	211	274	60	91	121	181

PV ez-Rack SolarRoof Interface spacing table for penetrative tilt legs (Cont.)

Type of Rail ER-R-ECO (see [Note 12](#) for other compatible rails)
 Solar Panel Dimension 2 m x 1 m (see [Note 25](#) for other panel sizes)
 Terrain Category 2.5

Angle against horizontal - $30^\circ < \alpha \leq 60^\circ$

Wind Region	Building Height (m)																			
	H ≤ 5				5 < H ≤ 10				10 < H ≤ 15				15 < H ≤ 20				20 < H ≤ 30			
	Corner	Edge	Intermediate	Internal	Corner	Edge	Intermediate	Internal	Corner	Edge	Intermediate	Internal	Corner	Edge	Intermediate	Internal	Corner	Edge	Intermediate	Internal
A	709	1024	1229	1418	638	976	1185	1328	596	968	1106	1291	533	817	1022	1226	323	484	645	968
B	452	690	936	1140	407	671	950	1140	388	604	837	1088	307	460	613	920	220	329	439	659
C	323	484	645	968	278	417	556	835	274	411	548	822	206	308	411	617	117	176	235	352
D	228	342	456	684	221	332	442	664	168	251	335	503	161	241	322	482	94	141	188	282

PV ez-Rack SolarRoof Interface spacing table for penetrative tilt legs

Type of Rail ER-R-ECO (see [Note 12](#) for other compatible rails)
 Solar Panel Dimension 2 m x 1 m (see [Note 25](#) for other panel sizes)
 Terrain Category 3

Angle against horizontal < 10°

Wind Region	Building Height (m)																			
	H ≤ 5				5 < H ≤ 10				10 < H ≤ 15				15 < H ≤ 20				20 < H ≤ 30			
	Corner	Edge	Intermediate	Internal	Corner	Edge	Intermediate	Internal	Corner	Edge	Intermediate	Internal	Corner	Edge	Intermediate	Internal	Corner	Edge	Intermediate	Internal
A	762	1154	1524	1905	693	1051	1387	1733	670	1016	1341	1676	560	848	1120	1400	450	675	900	1350
B	566	858	1132	1647	532	806	1064	1330	521	789	1042	1302	442	669	883	1104	331	497	662	994
C	492	746	985	1231	405	614	811	1013	388	588	777	971	285	432	570	712	208	312	416	624
D	379	574	757	947	341	516	682	852	241	366	483	604	227	344	454	568	166	249	331	497

Angle against horizontal - 10° ≤ α < 15°

Wind Region	Building Height (m)																			
	H ≤ 5				5 < H ≤ 10				10 < H ≤ 15				15 < H ≤ 20				20 < H ≤ 30			
	Corner	Edge	Intermediate	Internal	Corner	Edge	Intermediate	Internal	Corner	Edge	Intermediate	Internal	Corner	Edge	Intermediate	Internal	Corner	Edge	Intermediate	Internal
A	693	1051	1387	1699	624	945	1248	1560	582	882	1165	1456	491	745	983	1229	379	569	758	1138
B	493	747	986	1232	419	635	838	1047	355	538	710	887	346	524	692	865	242	363	484	726
C	437	662	874	1092	310	470	621	776	235	356	469	587	202	305	403	504	130	195	260	390
D	354	537	709	886	241	365	482	602	138	209	276	345	159	242	319	399	107	160	213	320

Angle against horizontal - 15° ≤ α < 20°

Wind Region	Building Height (m)																			
	H ≤ 5				5 < H ≤ 10				10 < H ≤ 15				15 < H ≤ 20				20 < H ≤ 30			
	Corner	Edge	Intermediate	Internal	Corner	Edge	Intermediate	Internal	Corner	Edge	Intermediate	Internal	Corner	Edge	Intermediate	Internal	Corner	Edge	Intermediate	Internal
A	655	993	1310	1605	537	814	1075	1343	524	794	1048	1310	464	704	929	1161	358	538	717	1075
B	445	674	889	1111	333	505	667	834	311	471	622	778	262	397	524	655	193	289	385	578
C	408	617	815	1019	265	401	530	662	233	353	466	583	172	261	344	430	110	166	221	331
D	330	500	660	826	248	375	495	619	173	263	347	433	149	225	297	372	97	146	194	291

PV ez-Rack SolarRoof Interface spacing table for penetrative tilt legs (Cont.)

Type of Rail ER-R-ECO (see [Note 12](#) for other compatible rails)
 Solar Panel Dimension 2 m x 1 m (see [Note 25](#) for other panel sizes)
 Terrain Category 3

Angle against horizontal - $20^\circ \leq \alpha < 25^\circ$

Wind Region	Building Height (m)																			
	H ≤ 5				5 < H ≤ 10				10 < H ≤ 15				15 < H ≤ 20				20 < H ≤ 30			
	Corner	Edge	Intermediate	Internal	Corner	Edge	Intermediate	Internal	Corner	Edge	Intermediate	Internal	Corner	Edge	Intermediate	Internal	Corner	Edge	Intermediate	Internal
A	575	880	1150	1495	472	721	943	1226	460	704	920	1196	387	593	775	1007	310	464	619	929
B	386	590	771	1002	289	442	578	752	270	413	540	702	217	332	434	565	159	239	319	478
C	358	547	715	930	232	356	465	604	217	332	434	564	144	220	288	375	101	151	201	302
D	290	443	580	754	217	332	435	565	152	233	304	396	141	216	283	367	85	127	170	254

Angle against horizontal - $25^\circ \leq \alpha < 30^\circ$

Wind Region	Building Height (m)																			
	H ≤ 5				5 < H ≤ 10				10 < H ≤ 15				15 < H ≤ 20				20 < H ≤ 30			
	Corner	Edge	Intermediate	Internal	Corner	Edge	Intermediate	Internal	Corner	Edge	Intermediate	Internal	Corner	Edge	Intermediate	Internal	Corner	Edge	Intermediate	Internal
A	535	818	1070	1390	439	671	877	1140	428	654	856	1112	356	544	711	925	288	432	576	864
B	350	535	700	910	245	375	490	637	245	375	490	637	197	301	394	512	158	237	315	473
C	324	495	648	842	211	322	421	548	197	301	393	511	131	200	261	339	99	148	197	296
D	255	389	509	662	191	292	382	496	134	204	267	347	115	175	229	298	81	122	162	243

Angle against horizontal - $\alpha = 30^\circ$

Wind Region	Building Height (m)																			
	H ≤ 5				5 < H ≤ 10				10 < H ≤ 15				15 < H ≤ 20				20 < H ≤ 30			
	Corner	Edge	Intermediate	Internal	Corner	Edge	Intermediate	Internal	Corner	Edge	Intermediate	Internal	Corner	Edge	Intermediate	Internal	Corner	Edge	Intermediate	Internal
A	480	734	960	1248	393	602	787	1023	384	587	768	998	302	462	605	786	240	360	480	721
B	314	480	628	816	220	336	440	571	213	326	427	555	177	270	354	460	125	187	250	375
C	291	445	581	756	179	274	358	465	176	270	353	459	125	191	249	324	79	118	157	236
D	225	344	450	585	171	262	342	445	123	188	246	320	110	168	219	285	63	94	126	189

PV ez-Rack SolarRoof Interface spacing table for penetrative tilt legs (Cont.)

Type of Rail ER-R-ECO (see [Note 12](#) for other compatible rails)
 Solar Panel Dimension 2 m x 1 m (see [Note 25](#) for other panel sizes)
 Terrain Category 3

Angle against horizontal - $30^\circ < \alpha \leq 60^\circ$

Wind Region	Building Height (m)																			
	H ≤ 5				5 < H ≤ 10				10 < H ≤ 15				15 < H ≤ 20				20 < H ≤ 30			
	Corner	Edge	Intermediate	Internal	Corner	Edge	Intermediate	Internal	Corner	Edge	Intermediate	Internal	Corner	Edge	Intermediate	Internal	Corner	Edge	Intermediate	Internal
A	741	1071	1285	1483	667	1021	1239	1388	623	1012	1157	1349	557	855	1068	1282	354	531	708	1063
B	472	721	979	1191	426	701	993	1192	406	632	875	1137	321	481	641	962	237	356	475	712
C	337	506	675	1012	291	436	582	873	287	430	573	860	215	322	430	645	127	191	254	382
D	238	358	477	715	231	347	462	694	175	263	350	526	168	252	336	504	102	153	204	306

General Notes

Note 1. This engineering document was designed to cater for most common installation scenarios however, it does not cater for all of them. Contact Clenergy if you are unable to comply with any of the installation specifications listed on this document.

Importance level	Structure type examples	Annual probability of exceedance for a design working life of 25 years
1	Fences, utility posts, isolated minor facilities, minor temporary facilities and small ground mount installations (up to 20 kw).	1/100 - 100 years
2	Residential shed or garage, small isolated warehouses, isolated farm sheds, residential carports, medium ground mount installations (up to 100 kw) and one or double storey dwelling.	1/200 – 200 years
3	Buildings and facilities where a large group of people can congregate in one area, commercial buildings, schools, aged cares, large office buildings, large commercial warehouses, large ground mount installations, multi-storey dwelling and churches.	1/500 – 500 years
4	Buildings and facilities designated as essential facilities such as medical emergency or surgery facilities, universities, police stations, emergency shelters, High rise buildings (more than 40 storeys) airports and government buildings.	1/1000 – 1000 years

Note 2. The spacing information in this document has been designed to be compliant with the capacity of the below items:

- Mounting system components, including the fixings, capacity and rail deflection.
- Buildex- 14 - 11 x 70 Hex Head Zips with 16 mm Aluminium Bonded Washer.

Note 3. This certificate only covers the assessment of the Clenergy PV mounting system, including the components listed on note 2 and 12. Assessment of the roof structure, PV panels and other fixings are to be checked by the installer/contractor, if necessary.

Note 4. Roof pitch between 1° and < 10° when rails run parallel to the roof pitch (Figure 1) and 1° and < 22° when rails run perpendicular to the roof pitch (Figure 2).

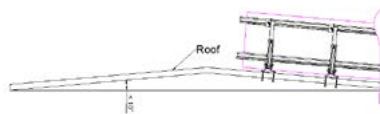

Figure 1. Rails running parallel to roof pitch

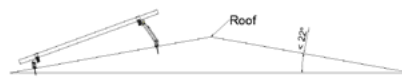

Figure 2. Rails running perpendicular to roof pitch

Note 5. Fixing spacings were calculated using **two screws** per tilt leg on Steel Purlins G450 1.5mm and 35 mm Timber F7 (Pine).

Note 6. Reduction factors using **one screw** per tilt leg and depending on the type of tophat, purlin or batten as per the below table

Purlin Material	Purlin thickness (mm)	Min. embedment (mm)	Spacing +/- (WR A)	Spacing +/- (WR B)	Spacing +/- (WR C)	Spacing +/- (WR D)
Timber (Pine F7)	-	25	-65%	-65%	Contact Clenergy	Contact Clenergy
Timber (Pine F7)	-	30	-40%	-40%	-75%	Contact Clenergy
Timber (Pine F7)	-	35	-20%	-25%	-50%	-85%
Timber (Hardwood F17)	-	25	-5%	-5%	-15%	-40%
Timber (Hardwood F17)	-	30	-	-	-5%	-20%
Timber (Hardwood F17)	-	35	-	-	-5%	-20%
Metal (G550)	0.42	-	Contact Clenergy	Contact Clenergy	Contact Clenergy	Contact Clenergy
Metal (G550)	0.48	-	Contact Clenergy	Contact Clenergy	Contact Clenergy	Contact Clenergy
Metal (G550)	0.55	-	Contact Clenergy	Contact Clenergy	Contact Clenergy	Contact Clenergy
Metal (G550)	0.75	-	-90%	Contact Clenergy	Contact Clenergy	Contact Clenergy
Metal (G450)	1.2	-	-75%	-80%	Contact Clenergy	Contact Clenergy
Metal (G450)	1.5	-	-45%	-50%	-50%	-65%
Metal (G450)	1.9	-	-	-	-5%	-20%
Metal (G450)	2.4	-	-	-	-5%	-10%

Note 7. Increase or reduction factors using **two screws** per tilt leg and depending on the type of tophat, purlin or batten as per the below table

Purlin Material	Purlin thickness (mm)	Min. embedment (mm)	Spacing +/- (WR A)	Spacing +/- (WR B)	Spacing +/- (WR C)	Spacing +/- (WR D)
Timber (Pine F7)	-	25	-	-5%	-10%	-10%
Timber (Pine F7)	-	30	-	-5%	-10%	-10%
Timber (Pine F7)	-	35	-	-	-	-
Timber (Hardwood F17)	-	25	-	-	+5%	+10%
Timber (Hardwood F17)	-	30	-	-	+5%	+10%
Timber (Hardwood F17)	-	35	-	-	+10%	+20%
Metal (G550)	0.42	-	-80%	-80%	Contact Clenergy	Contact Clenergy
Metal (G550)	0.48	-	-40%	-60%	-70%	-85%
Metal (G550)	0.55	-	-25%	-30%	-55%	-70%
Metal (G550)	0.75	-	-12%	-15%	-25%	-45%
Metal (G450)	1.2	-	-5%	-10%	-15%	-20%
Metal (G450)	1.5	-	-	-	-	-
Metal (G450)	1.9	-	-	-	+5%	+10%
Metal (G450)	2.4	-	-	-	+5%	+10%

Note 8. If any of the screws of the interfaces go into pre-existing holes, they will have to be one size up compared to the screws that were previously installed. This is to ensure that the pullout capacity remains the same or higher.

Note 9. The most conservative spacing has to be used if one panel or panel row fall between two roof zones.

Note 10. Minimum purlin steel grade to be G450 and timber grade members: F7 (Pine) and F17 (Hardwood).

Note 11. In case the installation is done with one screw and the purlin thickness differs from Note 6, a site-specific certificate shall be issued. Contact Clenergy for more information.

Note 12. The following components are satisfied for use according to AS/NZS 1664.1:1997-Amdt 1:1999 and AS/NZS 1170.2:2011 Amdt 4-2016.

Components	Part No.	Description
ECO-Rail	ER-R-ECO/XXXX	ECO Rail
Splice	ER-SP-ECO	PV-ezRack Splice for ECO rail
Australian Made Mill	R-ECO/XXXX/AUMF	PV-ezRack Australian Made Mill Finish ECO Rail
Black ECO-Rail	ER-R-ECO/XXXX/BA	Black ECO Rail
Black Splice ECO Rail	ER-SP-ECO/BA	Splice ECO Rail Black
Inter Clamp	ER-IC-STXX	Inter Clamp = Clamp + Z-Module + Bolt
End Clamp	ER-EC-STXX	End Clamp = Clamp + Z-Module + Bolt
Clamp	C-U/30/46-G	Universal Clamp for Frame Height 30-46mm with Grounding Clip
Clamp	C-U/30/46	Universal Clamp for Frame Height 30-46mm
End Clamp	ER-EC-DU35/40	End Clamp dual 35 or 40mm
End Clamp	ER-EC-DU40/46	End Clamp dual 40 or 46mm
Inter Security Clamp	ER-IC-STXX/S	Inter Clamp = Clamp + Z-Module + Security Bolt
End Security Clamp	ER-EC-STXX/S	End Clamp = Clamp + Z-Module + Security Bolt
Tilt Legs	ER-TL-10/15	10°/15° Adjustable Tilt Legs

Components	Part No.	Description
Tilt Legs	ER-TL-15/30	15°/30° Adjustable Tilt Legs
Tilt Legs	ER-TL-30/60	30°/60° Adjustable Tilt Legs
Tilt Legs	ER-TL-10/15/PS	10°/15° Adjustable Tilt Legs, Preassembly
Tilt Legs	ER-TL-15/30/PS	15°/30° Adjustable Tilt Legs, Preassembly
Tilt Legs	TL-10/15/L/PS	10°/15° L Feet Adjustable Tilt Legs, Preassembly
Tilt Legs	TL-15/30/L/PS	15°/30° L Feet Adjustable Tilt Legs, Preassembly
Tilt Legs	ER-TL-5/PS	5° Fixed Tilt Legs, Preassembly
Tilt Legs	ER-TL-10/PS	10° Fixed Tilt Legs, Preassembly
Tilt Legs	ER-TL-FF	Front Foot of Tilt Legs
Black Tilt Legs	ER-TL-10/15/BA	Black 10°/15° Adjustable Tilt Legs
Black Tilt Legs	ER-TL-15/30/BA	Black 15°/30° Adjustable Tilt Legs
End Clamp (*)	EC-FL/GE/XX/XX	End Clamp for Frameless Module (glued EPDM)
Inter Clamp (*)	IC-FL/GE/XX/XX	Inter Clamp for Frameless Module (glued EPDM)
End Clamp (*)	ER-EC-FL/XX/XX	End Clamp for Frameless Module
Inter Clamp (*)	ER-IC-FL/XX/XX	Inter Clamp for Frameless Module
Black End Clamp (*)	EC-FL/GE/XX/XX/B	Black End Clamp for Frameless Module (glued EPDM)
Black Inter Clamp (*)	IC-FL/GE/XX/XX/B	Black Inter Clamp for Frameless Module (glued EPDM)

Components	Part No.	Description
Mid Clamp XX Black	ER-IC-STXXB	Inter Clamp XX Black
End Clamp XX Black	ER-EC-STXXB	End Clamp XX Black
Adapter for tilt leg	EZ-AD-C110	Adapter for tilt leg on corrugated roofs
Black Universal Clamp	C-U/30/46/BA	Black Universal Clamp
Black Universal Clamp	C-U/30/46-G/BA	Black Universal Clamp with grounding clip

(*) Subject to the panel manufacturer's installation guide.

Note 13. For Terrain Category (TC) definition. Refer to clause 4.2.1 of AS/NZS 1170.2:2011 (R2016) for more information.

Note 14. Topographic Multiplier (Mt) taken as 1.0. Refer to clause 4.4 of AS/NZS 1170.2:2011 (R2016) for more information.

Note 15. Shielding Multiplier (Ms) taken as 1.0. Refer to clause 4.3 of AS/NZS 1170.2:2011 (R2016) for more information.

Note 16. Wind Direction Multiplier (Md) taken as 1.0. Refer to clause 3.3 of AS/NZS 1170.2:2011 (R2016) for more information.

Note 17. Clamping zone of the PV panels should be according to the manufacturer's specifications.

Note 18. Capacities checked and compared against testing data from Clenergy Australia and NATA certified testing.

Note 19. Rail overhang ends where the panel finishes and this should be less than 40% of the last installed interface spacing.

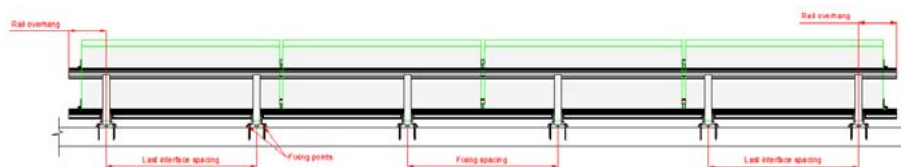

Note 20. From the date of publication onwards, any amendment made to any of the above-mentioned Standards will make this report outdated and a new one will have to be released, unless the amendment has no implications on this certificate.

Note 21. All components from Clenergy must be installed according to manufacturer's specification and the instructions shown in the relevant installation manual. Please check the Clenergy Australia website or contact them for access to the most recent installation manuals.

Note 22. Only hip and gable roofs installations are covered on this certificate. Contact Clenergy if you are planning to install on a different roof type such as curved, multi-span (pitched and saw-tooth), mansard, circular bin, silo, tank, pitched free, troughed free, hypar free, canopy, awning and cantilvered roof.

Note 23. No consideration has been taken on the effect of snow loads. In case the roof is located in a snow prone area, a project specific design must be completed.

Note 24. No consideration has been taken on the effect of earthquake loads.

Note 25. This Engineering report is based on 2 m x 1 m panels and two rails per panel. However, a percentage increase could be applied on all interface spacings as shown on the following table.

Number of rails per panel	Panel length (mm)	Spacing +/-	
		W.R – A & B	W.R – C & D
2 rails	≤ 1700	+ 6 %	+ 10 %
2 rails	≤ 1800	+ 4 %	+ 7 %
2 rails	≤ 1900	0 %	+ 5 %
2 rails	≤ 2000	0 %	0 %
2 rails	≤ 2100	- 10 %	- 6 %
2 rails	≤ 2200	- 18 %	- 12 %
2 rails	≤ 2300	- 20 %	- 12 %
2 rails	≤ 2400	- 25 %	- 15 %

Note 26. Panel width cannot exceed 1.20 m for any of the above panel length dimensions and panel weight cannot exceed 15 kg/m².

Note 27. If the installation is located in ISO corrosivity category C4 reduce the interface spacing by 5%. If the installation is located in ISO corrosivity category C5 reduce the interface spacing by 25%. For more details refer to Clenergy’s warranty document.

Note 28. Final tilt “α” identification as per below

Standard tilt

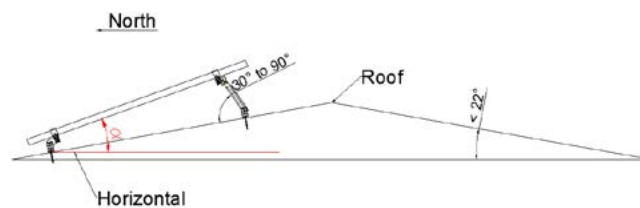

Back leg angle between 30° and 90°

Reverse tilt

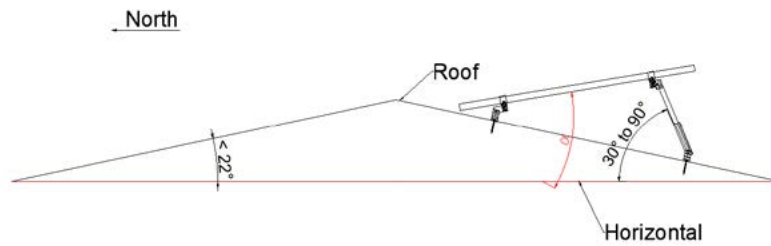

Back leg angle between 30° and 90°

ECO – Rail parallel to ribs

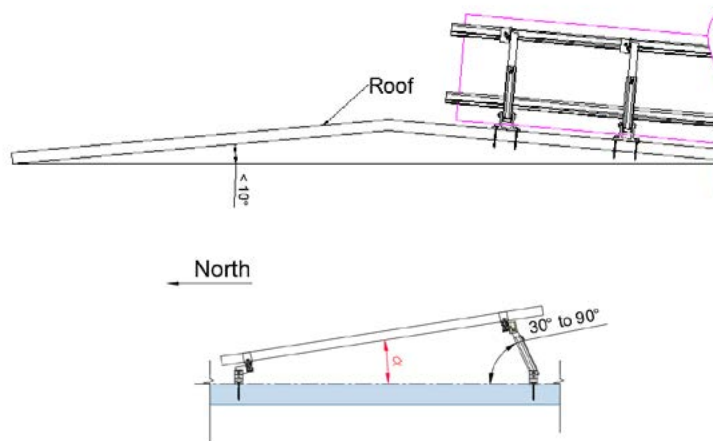

Back leg angle between 30° and 90°

Note 29. Roof Zone definition to be calculated as per below:

- Step 1.** Determine building height (h), width (b) and length (d).
- Step 2.** Choose the lowest value between "h", "b x 0.2" and "d x 0.2".
- Step 3.** The lowest value on Step 2, equates to a.

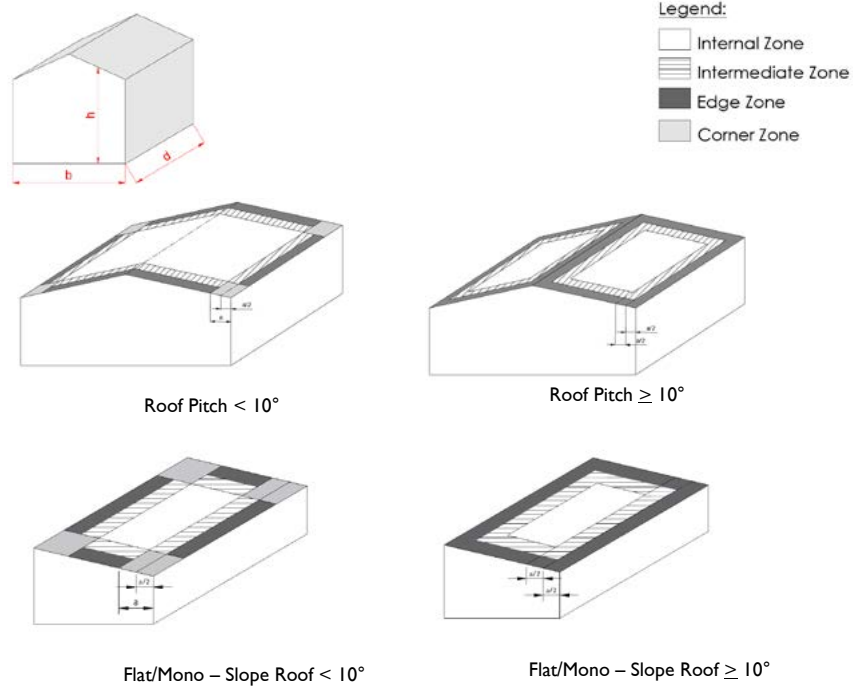

Example for penetrative tilted systems

- Wind Region: B
- Terrain Category: 3
- Building height: 5m
- Roof pitch: 2°
- Panel tilt: 10°
- Standard tilt
- Number of screws per tilt leg: 1
- Panel dimensions: 2.1 m x 1.1 m
- Purlin thickness: 1.5 mm
- Panel reduction factor: -10% (Note 23)
- One screw reduction factor: -5% (Note 6)
- Fixing spacing as per below:
 - o Internal: 1050 mm
 - o Intermediate: 838 mm
 - o Edge: 635 mm
 - o Corner: 420 mm



PV-ezRACK®

Clenergy

1/10 Duerdin St
Clayton VIC 2168
Australia

Phone: +61 3 9239 8088
Email: sales@clenergy.com.au
Web: www.clenergy.com.au

 @ClenergyGlobal / @ClenergyClub / ClenergyAUS  @Clenergy  @ClenergyClub
 @Clenergy_global  @Clenergy

A Clenergy Technologies Company